

**A Novel and Practical Approach  
To Distribution System Performance Enhancement  
Using A Fuzzy Capacitor Allocation Method**

by

**Hok-Nin Ng**

A thesis

presented to the University of Waterloo

in fulfilment of the

thesis requirement for the degree of

**Doctor of Philosophy**

in

**Electrical Engineering**

**Waterloo, Ontario, Canada, 1999**

**© Hok-Nin Ng 1999**



National Library  
of Canada

Acquisitions and  
Bibliographic Services

395 Wellington Street  
Ottawa ON K1A 0N4  
Canada

Bibliothèque nationale  
du Canada

Acquisitions et  
services bibliographiques

395, rue Wellington  
Ottawa ON K1A 0N4  
Canada

*Your file Votre référence*

*Our file Notre référence*

The author has granted a non-exclusive licence allowing the National Library of Canada to reproduce, loan, distribute or sell copies of this thesis in microform, paper or electronic formats.

The author retains ownership of the copyright in this thesis. Neither the thesis nor substantial extracts from it may be printed or otherwise reproduced without the author's permission.

L'auteur a accordé une licence non exclusive permettant à la Bibliothèque nationale du Canada de reproduire, prêter, distribuer ou vendre des copies de cette thèse sous la forme de microfiche/film, de reproduction sur papier ou sur format électronique.

L'auteur conserve la propriété du droit d'auteur qui protège cette thèse. Ni la thèse ni des extraits substantiels de celle-ci ne doivent être imprimés ou autrement reproduits sans son autorisation.

0-612-51216-9

**Canada**

**The University of Waterloo requires the signature of all persons using or photocopying this thesis. Please sign below, and give address and date.**

## **Abstract**

As the electrical utility business enters into a deregulated environment, distribution companies will strive to operate at the utmost economic efficiency. Loss reduction through the use of capacitor placement is an effective means of decreasing the operating costs of a utility. This thesis details a practical and flexible approach for distribution system loss reduction and performance enhancement using a fuzzy capacitor allocation technique. The proposed method takes advantage of the concepts of fuzzy set theory to model uncertain parameters of the distribution system, and to represent knowledge and heuristics that can be used to optimize the operation of the distribution system. A fuzzy expert system is used to determine suitable locations for capacitor installations and a multi-objective fuzzy optimization approach is used to determine the proper sizes of the capacitors. Effective control of capacitors is performed by another fuzzy expert system. Computer simulations performed, have clearly demonstrated the advantages and the significant contributions of the methods in this thesis for distribution system loss reduction and performance enhancement.

## **Acknowledgements**

I would like to thank my supervisors Dr. Magdy Salama and Dr. Aziz Chikhani for their invaluable academic guidance in seeing through this thesis to its successful completion. They have always provided confidence and enthusiasm for my work. I am grateful for having had the opportunity to study and work under their supervision.

I would also like to thank Mr. Steve Cress of Ontario Hydro Technologies for many wise insights and discussions on the technical and business practices of utility companies. I also appreciate his comments on many of the ideas in this thesis.

Finally, I would like to acknowledge my family and close friends who have made a contribution in one form or another to the completion of this thesis

# Table of Contents

<b>1. Introduction .....</b>	<b>1</b>
1.1 <i>Background .....</i>	<i>1</i>
1.2 <i>Thesis Objectives and Overview .....</i>	<i>3</i>
1.3 <i>Thesis Organization .....</i>	<i>4</i>
<b>2 Distribution System Loss Reduction Techniques .....</b>	<b>5</b>
2.1 <i>Introduction.....</i>	<i>5</i>
2.1.1 <b>Demand Side Management .....</b>	<b>6</b>
2.1.2 <b>Distribution Transformer Load Management .....</b>	<b>7</b>
2.1.3 <b>Reconfiguration.....</b>	<b>7</b>
2.1.4 <b>Reconductoring .....</b>	<b>8</b>
2.1.5 <b>Voltage Uprating.....</b>	<b>8</b>
2.1.6 <b>Conservative Voltage Reduction.....</b>	<b>9</b>
2.1.7 <b>Shunt Capacitor Installation.....</b>	<b>9</b>
2.2 <i>Practical Choices for Loss Reduction.....</i>	<i>10</i>
2.3 <i>Summary.....</i>	<i>11</i>

<b>3</b>	<b>Capacitor Placement</b> .....	<b>12</b>
3.1	<i>Introduction</i> .....	12
3.2	<i>Application of Capacitors to Distribution Systems</i> .....	13
3.3	<i>Optimal Capacitor Allocation</i> .....	14
3.3.1	<b>Analytical Methods</b> .....	15
3.3.2	<b>Mathematical Programming Methods</b> .....	17
3.3.3	<b>Heuristic Methods</b> .....	19
3.3.4	<b>AI-Based Methods</b> .....	20
3.3.4.1	<b>Genetic Algorithms</b> .....	21
3.3.4.2	<b>Expert Systems</b> .....	22
3.3.4.3	<b>Simulated Annealing</b> .....	22
3.3.4.4	<b>Artificial Neural Networks</b> .....	23
3.3.4.5	<b>Fuzzy Set Theory</b> .....	25
3.3.4.6	<b>Summary of AI Methods</b> .....	25
3.4	<i>An Assessment of the Available Capacitor Allocation Techniques</i> .....	26
3.4.1	<b>Capacitor Allocation Problem to be Solved</b> .....	27
3.4.2	<b>Complexity of Problem</b> .....	27
3.4.3	<b>Accuracy of Results</b> .....	28
3.4.4	<b>Practicality</b> .....	28

3.5	<i>Achieving a Complete Capacitor Allocation System</i> .....	31
3.6	<i>Summary</i> .....	32
<b>4</b>	<b>Applications of Fuzzy Set Theory in Power Systems</b> .....	<b>33</b>
4.1	<i>Introduction</i> .....	33
4.2	<i>A Brief Review of Fuzzy Set Theory</i> .....	34
4.3	<i>Applications of Fuzzy Set Theory to Power Systems</i> .....	36
4.3.1	<b>Load Flow Analysis and Optimal Power Flow</b> .....	37
4.3.2	<b>Load Forecasting and Planning</b> .....	38
4.3.2.1	<b>Short-Term Load Forecasting</b> .....	39
4.3.2.2	<b>Power System Planning</b> .....	40
4.3.3	<b>Reactive Power and Voltage Control</b> .....	40
4.3.4	<b>Power System Protection</b> .....	41
4.4	<i>Summary</i> .....	42
<b>5</b>	<b>Objectives of Proposed Method</b> .....	<b>44</b>
5.1	<i>Introduction</i> .....	44
5.2	<i>Outline of Solution Strategy</i> .....	45
5.2.1	<b>Load Flow Models</b> .....	47
5.2.2	<b>Planning Module</b> .....	47

5.2.3	Control Module .....	48
5.3	<i>Summary</i> .....	48
<b>6</b>	<b>Capacitor Planning .....</b>	<b>50</b>
6.1	<i>Introduction</i> .....	50
6.2	<i>Capacitor Location Selection by Approximate Reasoning</i> .....	50
6.2.1	Framework of Capacitor Allocation Approach.....	51
6.2.2	Fuzzy Rules for Location of Suitable Capacitor Installations.....	53
6.2.3	Fuzzy Inferencing and Deffuzification Techniques .....	57
6.3	<i>Capacitor Sizing</i> .....	61
6.3.1	Multi-Objective Fuzzy Optimization .....	61
6.3.2	Capacitor Sizing Using Multi-Objective Fuzzy Optimization.....	64
6.4	<i>Application of the Planning Method</i> .....	69
6.4.1	First Iteration .....	71
6.5	<i>Switched Capacitors</i> .....	80
6.5.1	Determining Switched Capacitors.....	82
6.5.2	Application of the Switched Capacitor Planning Method.....	86
6.6	<i>Summary</i> .....	89

<b>7</b>	<b>Control of Capacitors.....</b>	<b>90</b>
7.1	<i>Introduction.....</i>	90
7.2	<i>A Review Capacitor Dispatch Schemes .....</i>	91
7.3	<i>Capacitor Control by Fuzzy Inferencing.....</i>	92
7.4	<i>FES For Capacitor Control .....</i>	93
7.5	<i>An Example of Using the Fuzzy Capacitor Controller .....</i>	96
7.5.1	<i>Simulation Results .....</i>	101
7.6	<i>Summary.....</i>	105
<b>8</b>	<b>Conservative Voltage Reduction.....</b>	<b>106</b>
8.1	<i>Introduction.....</i>	106
8.2	<i>Load Flow Analysis for Distribution Systems .....</i>	107
8.2.1	<i>Ladder Network Theory .....</i>	107
8.2.2	<i>Load Sensitivity to Voltage.....</i>	110
8.3	<i>Load Model Studies.....</i>	111
8.3.1	<i>Capacitor Allocation and the Application of CVR .....</i>	114
8.4	<i>Summary.....</i>	116

<b>9</b>	<b>Conclusions and Recommendations .....</b>	<b>117</b>
9.1	<i>Conclusions.....</i>	<i>117</i>
9.2	<i>Recommendations for Future Work.....</i>	<i>119</i>

## **List of Tables**

<b>Table 2.1: Benefit/Cost Ratios Comparison of Loss Reduction Methods .....</b>	<b>10</b>
<b>Table 3.1: Comparison of Capacitor Allocation Methods. ....</b>	<b>26</b>
<b>Table 6.1: Fuzzy Decision Matrix.....</b>	<b>54</b>
<b>Table 6.2: Load and Line Data for 34-Bus Distribution System .....</b>	<b>70</b>
<b>Table 6.3: Results.....</b>	<b>80</b>
<b>Table 7.1: Decision Matrix for Capacitor Switching .....</b>	<b>94</b>
<b>Table 7.2: Load Types of 34 Bus System .....</b>	<b>98</b>
<b>Table 7.3: Weekday Capacitor Dispatch.....</b>	<b>102</b>
<b>Table 7.4: Weekend Capacitor Dispatch.....</b>	<b>102</b>

## List of Figures

Figure 3.1: Structure of an Artificial Neural Network .....	24
Figure 4.1: Membership Functions for <i>Light, Medium, and Heavy</i> Loads .....	35
Figure 5.1: Flow of Information.....	46
Figure 6.1: Framework of Approach.....	52
Figure 6.2: Membership Functions for Power Loss Index.....	55
Figure 6.3: Membership Functions for Voltage .....	55
Figure 6.4: Membership Functions for Capacitor Placement Suitability.....	56
Figure 6.5: Partitioning of Voltage Membership Functions .....	57
Figure 6.6: Definition of Fuzzy Membership Functions.....	58
Figure 6.7: Fuzzy Rule Definitions .....	59
Figure 6.8: Membership Function of Cost Objective.....	67
Figure 6.9: Membership Function of Voltage Constraint .....	68
Figure 6.10: One-Line Diagram of 34-Bus Distribution System.....	69
Figure 6.11: Membership Functions for the Power Loss Index and Voltage .....	71
Figure 6.12: Graphical Inferencing of Rule 1 .....	73
Figure 6.13: Graphical Inferencing of Rule 2 .....	74
Figure 6.14: Graphical Inferencing of Rule 3 .....	75
Figure 6.15: Graphical Inferencing of Rule 4 .....	76
Figure 6.16: Aggregated Membership Function and Defuzzified Value .....	77
Figure 6.17: Capacitor Cost by Size.....	78

<b>Figure 6.18: Membership Functions for Load Factor .....</b>	<b>86</b>
<b>Figure 6.19: Membership Functions of Load Factor .....</b>	<b>87</b>
<b>Figure 7.1: Fuzzy Capacitor Control Module .....</b>	<b>93</b>
<b>Figure 7.2: Daily Load Profile for Industrial Loads.....</b>	<b>99</b>
<b>Figure 7.3: Daily Load Profile for Residential Loads on a Winter Weekday .....</b>	<b>99</b>
<b>Figure 7.4: Daily Load Profile for Residential Loads on a Winter Weekend .....</b>	<b>100</b>
<b>Figure 7.5: Daily Load Profile for Residential Loads on a Summer Weekday .....</b>	<b>100</b>
<b>Figure 7.6: Daily Load Profile for Residential Loads on a Summer Weekend .....</b>	<b>101</b>
<b>Figure 7.7: Energy Loss Reduction for a Typical Winter Weekday .....</b>	<b>103</b>
<b>Figure 7.8: Energy Loss Reduction for a Typical Winter Weekend Day .....</b>	<b>103</b>
<b>Figure 7.9: Energy Loss Reduction for a Typical Summer Weekday .....</b>	<b>104</b>
<b>Figure 7.10: Energy Loss Reduction for a Typical Summer Weekend Day .....</b>	<b>104</b>
<b>Figure 8.1: Ladder Network Representation of a Single Feeder.....</b>	<b>108</b>
<b>Figure 8.2: Voltage Reduction vs Losses for Various Load Models .....</b>	<b>112</b>
<b>Figure 8.3: Voltage Reduction vs Demand for Various Load Models.....</b>	<b>113</b>
<b>Figure 8.4: Voltage Profile of 34 Bus Feeder .....</b>	<b>114</b>

## **Glossary**

<b>AI</b>	<b>Artificial Intelligence</b>
<b>ANN</b>	<b>Artificial Neural Network</b>
<b>BES</b>	<b>Bulk Electricity Supplier</b>
<b>CVR</b>	<b>Conservative Voltage Reduction</b>
<b>DSM</b>	<b>Demand Side Management</b>
<b>ES</b>	<b>Expert System</b>
<b>FES</b>	<b>Fuzzy Expert System</b>
<b>FST</b>	<b>Fuzzy Set Theory</b>
<b>GA</b>	<b>Genetic Algorithm</b>
<b>HE</b>	<b>Human Expertise</b>
<b>KBS</b>	<b>Knowledge-Based System</b>
<b>OPF</b>	<b>Optimal Power Flow</b>
<b>SA</b>	<b>Simulated Annealing</b>
<b>SCADA</b>	<b>Supervisory Control And Data Acquisition</b>
<b>TLE</b>	<b>Technical Literature Expertise</b>
<b>TOU</b>	<b>Time-Of-Use</b>

# **1. Introduction**

## **1.1 Background**

The Energy Competition Act [1] was introduced into legislation in June 1998 by the Ontario Government to call for the creation of a competitive market for the electrical utility business. Beginning in the year 2000, Ontario's electricity industry will operate in a deregulated environment. The key purposes of the Energy Competition Act are to:

- provide generators, retailers and consumers with non-discriminatory access to transmission and distribution systems in Ontario;
- protect the interests of consumers with respect to prices, reliability, and quality of electricity services;
- promote economic efficiency in the generation, transmission, and distribution of electricity;

- facilitate the maintenance of a financially viable electricity industry; and,
- facilitate energy efficiency and the use of cleaner, more environmentally benign energy sources in a manner consistent with the policies of the Government of Ontario.

Electrical utilities in the deregulated environment will strive to provide higher profits to the shareholders, and compete for a larger share of the market. In order for a utility to remain on competitive edge, it must constantly operate in an economically efficient and streamlined fashion. While cost-cutting measures can be applied on the administrative operations of a utility, a more effective means of diminishing the overall costs is loss reduction. For the Ontario Hydro system, up to 12% of total power generated is consumed as  $I^2R$  losses [2]. Two-thirds of these losses are incurred by at the distribution level. In an American study, the  $I^2R$  losses at the distribution level alone have been found to be as high as 13% of the total power generated [3]. Hence, loss reduction at the distribution level can represent large savings in a utility's marginal costs.

Efforts for loss reduction include Demand Side Management (DSM) policies, distribution transformer load management, reconfiguration, reconductoring, voltage uprating, Conservative Voltage Reduction (CVR), and shunt capacitor installation. Determining an effective loss reduction strategy can include any combination of the above programs. Performing a loss reduction feasibility study for a distribution system company is a considerable task. There is no set recipe for a distribution system engineer to follow for maximum loss reduction. Thus, an assessment guideline for

practical implementation of a loss reduction program is needed. This thesis details a practical and flexible approach for distribution system loss reduction and performance enhancement.

## **1.2 Thesis Objectives and Overview**

The objectives of this thesis are to:

- provide a guideline for the implementation of effective distribution system loss reduction using shunt capacitors;
- employ fuzzy set theory to account for uncertain information, incorporate engineering expertise, heuristics, and practical judgment into the decision process of optimizing distribution system performance;
- create a capacitor allocation system with a user-interactive interface that can be easily integrated into any utility's existing SCADA system; and,
- demonstrate the performance ability of the devised capacitor allocation loss reduction scheme by application to a distribution system.

In the development of achieving the above objectives, the following research has also been accomplished and included in this thesis:

- a thorough investigation of distribution system loss reduction methods available;
- a critical review of previous work in the area of capacitor allocation;
- a study of Fuzzy Set Theory (FST) and its application to power systems; and,

- an analysis of the effects of different load modeling approaches on loss calculations.

### **1.3 Thesis Organization**

The material in this thesis is organized into nine chapters as follows:

- Chapter 2 details the available methods for loss reduction;
- Chapter 3 surveys the capacitor allocation techniques in the literature;
- Chapter 4 reviews FST and its applications to power systems;
- Chapter 5 describes the fundamentals of the proposed distribution system loss reduction strategy;
- Chapter 6 presents the fuzzy capacitor allocation algorithm;
- Chapter 7 outlines fuzzy capacitor control;
- Chapter 8 explains the incorporation of CVR into the distribution system loss reduction scheme; and,
- Chapter 9 provides concluding remarks, an outline of novel contributions in capacitor allocation, and recommendations for future work.

## **2 Distribution System Loss Reduction Techniques**

### **2.1 Introduction**

The methods for loss reduction are numerous. They include Demand Side Management (DSM) programs, distribution transformer load management, reconfiguration, reconductoring, voltage up-rating, Conservative Voltage Reduction (CVR) and shunt capacitor installation. The next subsections describe each of the above loss reduction techniques and offer some insight into their effectiveness.

### **2.1.1 Demand Side Management**

Municipal utilities in Canada are billed an energy charge and a peak demand charge by a Bulk Electricity Supplier (BES). This billing structure encourages the utility to flatten the load curve so that the BES can reduce the dispatch of auxiliary generation. Thus, some utilities have set up DSM policies to recommend customers to defer the use of home appliances such as clothes washers, dryers and dishwashers to off-peak hours. To further increase the incentive of using electricity at off-peak times, some utilities have even established Time-Of-Use (TOU) rates with less expensive energy charges during off-peak hours. Some utilities such as the Toronto Hydro Electric Commission have even installed timers to switch off residential water heaters for brief moments during peak times to reduce the demand charge.

The effectiveness of a DSM program depends on the participation of the customers. Using certain household appliances at off-peak times may not be convenient for some customers. In some instances, the encouragement of using electricity at non-peak times has even caused new peaks to occur [4]. Furthermore, this form of power peak-shaving will have less effect in a deregulated environment as the producers of electricity are likely to only have a kWh rate and no kW rate for the demand. Ontario Hydro already only bills its rural utilities an energy charge, and no demand charge. Also, the municipal utilities have recently experienced a lowered demand charge, but an increase in the energy charge [5]. So, from an economic savings perspective, there is less motivation for the promotion of DSM programs.

### **2.1.2 Distribution Transformer Load Management**

Distribution transformer load management involves balancing the load between phases and resizing over- and under-utilized transformers to reduce losses. Ideally, phase currents and voltages of all distribution transformers would need to be monitored in order to practice distribution transformer load management properly. However, for most Canadian utilities, such measurements are only available at the substation level. To monitor every pole and pad mounted transformer downstream from the substation would prove to be costly. At the very least, distribution transformer load management can be practiced at the planning stages of a distribution system by sizing transformers for maximum energy efficiency [6].

### **2.1.3 Reconfiguration**

Many distribution systems have a radial structure and are equipped with sectionalizing switches for fault isolation or scheduled maintenance of a section. These switches can also be used to transfer loads between unevenly loaded feeders for minimizing losses. Loss reduction by reconfiguration is highly system dependent [7]. Reconfiguration is less likely to be effective for systems with few automatic sectionalizing switches.

### **2.1.4 Reconductoring**

It is obvious that the use of feeder conductors with larger cross-sectional areas has associated lower  $I^2R$  losses. The more expensive larger-sized cables and the installation costs are likely to forbid reconductoring as a feasible means for loss reduction. Moreover, feeder upgrades with heavier conductors can only be economically justified for older networks that are operating close to their design capacity.

### **2.1.5 Voltage Upgrading**

By increasing the primary distribution system voltage, the same amount of power can be delivered at lower currents, thus lowering losses. In the past decade, many municipal utilities have upgraded their primary distribution system voltage from 4kV to 13.8kV, and in some cases, 27.6kV. As result of a recent voltage conversion by the Toronto Hydro Electric Commission, the utility estimates savings of \$620 million over 25 years [8]. However, for Ontario Hydro Rural utilities, such an upgrade would not be feasible as the project would not have the same return on capital investment as with the Toronto Hydro Electric Commission [9].

### **2.1.6 Conservative Voltage Reduction**

Conservative Voltage Reduction (CVR) operates by reducing the substation transformer voltages by a few percent while keeping the secondary feeder voltage at acceptable levels. Several American utilities have found that up to 1% reduction in energy consumption can be achieved by 0.01 p.u. reduction in the voltage [10, 11]. Some utilities have only applied CVR for a duration no more than 10 minutes to reduce the peak demand charge. If continuous CVR is applied, it is done as a means for energy consumption reduction. This could also result in a reduction in revenues for the utility. However, in a deregulated environment, this can attract more customers as the utility can ensure that customers can also reduce their energy consumption and electricity bill.

### **2.1.7 Shunt Capacitor Installation**

The installation of shunt capacitors in primary distribution systems reduce losses by supplying reactive currents to oppose the out-of-phase component of the feeder currents required by inductive loads. It is this reduction or elimination of the reactive component of the currents that reduces the  $I^2R$  losses. Ontario Hydro Rural utilities have investigated and found that the use of shunt capacitors can result in a \$22.5 million net savings over 10 years from implementation in only 50% of their distribution systems [12]. B.C. Hydro is also experiencing reasonable loss reduction from a recent capacitor installation project for some of their distribution feeders [13].

## **2.2 Practical Choices for Loss Reduction**

Given that the majority of the losses are found at the distribution level, many utilities can achieve significant savings from the implementation of one or a combination of loss reduction methods outlined above. Benefit/cost ratios can be established to determine which loss reduction measures are the most suited for application. In a European study, benefit/cost ratios of various loss reduction schemes have been established [14]. These indices are tabulated in Table 2.1. The ranges for the benefit/cost ratios are highly variable. Capacitor placement, reconfiguration, and distribution transformer load management rank among the highest with benefit/cost ratios. Reconfiguration and distribution transformer load management may have greater benefits in Europe where the systems are more heavily loaded. In North America where the systems are not as heavily loaded, these two methods of loss reduction are not as effective. The report in [14] also indicates that capacitor placement remains as one of the most popular methods of loss reduction since it does not require as much capital expenditure as reconductoring or voltage uprating. Furthermore, distribution systems circuits always have an inductive component and proper capacitor placement will always result in some loss reduction. In addition, from an operation point of view, installation of fixed capacitors does not require any significant upgrade of SCADA (Supervisory Control And Data Acquisition) system equipment; whereas the implementation of a new reconfiguration scheme or transformer load management system would require a substantial increase of

additional SCADA capabilities of monitoring and control. These are capital costs not accounted for in [14]. Thus, capacitor placement is, in most cases, an ideal distribution system loss reduction measure a utility can choose to implement.

**Table 2.1: Benefit/Cost Ratios Comparison of Loss Reduction Methods**

Type of Loss Reduction Project	Benefit/Cost Ratio Range
Capacitor Placement	2 to 8
Reconductoring	0.6 to 7
Voltage Uprating	1.5 to 3
Reconfiguration	up to 13
Distribution Transformer Load Management	1 to 15

## **2.3 Summary**

This chapter has provided a brief review of loss reduction methods. A utility's choice of loss reduction program is very much system dependent. Since, the aggregate loads of distribution systems all have an inductive component, capacitor installation appears to be the most consistent for achieving loss reduction. In addition, capacitor placement has the added benefits of improved voltage profiles, and capacity release in distribution system apparatus. The next chapter critically surveys the capacitor allocation methods in the literature.

## **3 Capacitor Placement**

### **3.1 Introduction**

In the past, the primary functions of capacitors have been to regulate voltage and reactive power flows at the point of installation in a distribution system. However, capacitors are now more efficient, economical and readily available. They are an attractive option for energy and peak power loss reduction in the distribution system. This chapter outlines the application of shunt capacitors to distribution systems, describes the problem of optimal capacitor allocation, and provides a literature survey of the work done in optimal capacitor allocation.

## **3.2 Application of Capacitors to Distribution Systems**

Shunt capacitors are connected in parallel with the primary distribution feeders of a system. They supply the out-of-phase component of the current required by inductive loads. Typically, for distribution loads, the current lags the voltage. Thus, a shunt capacitor draws leading currents which counteracts against the lagging component of the current at the point of its installation. As a result, the power factor of the circuit is improved, a voltage rise occurs at the point of the capacitor installation, and more importantly, the reactive component of the current is reduced to lower the  $I^2R$  losses. When reactive power is supplied by generation, ratings of generators, transformers, transmission and distribution lines must be increased accordingly. However, when shunt capacitors are installed in a distribution system, the reactive power demand from generation is decreased, thus releasing savings in the capacity for generators, transformers, and distribution lines. In summary, the economical benefits of installation shunt capacitors in primary distribution systems are:

- reduced energy and peak power losses;
- improved voltage regulation;
- released capacity of distribution feeders;
- released substation capacity;

- released transmission capacity; and,
- released generation capacity.

Thus, the problem of optimal capacitor allocation involves determining the best locations, sizes and number of capacitors to install in a distribution system to achieve the most economic benefit. The next subsection will provide a critical review of the optimal capacitor allocation methods in the literature.

### **3.3 Optimal Capacitor Allocation**

Published literature describing capacitor placement algorithms are abundant. The Capacitor Subcommittee of the IEEE Transmission and Distribution Committee has published 10 bibliographies on power capacitors from 1950 to 1980 [15]. Moreover, the VAR Management Working Group of the IEEE System Control Subcommittee has published another bibliography on reactive power and voltage control in power systems [16]. The total publication count listed in these bibliographies is over 400, and many of these papers are specific to the problem of optimal capacitor allocation. Therefore, it would be an enormous task to survey all capacitor placement literature. Nonetheless, this chapter shows the progression of research in optimal capacitor placement and classifies the available algorithms by method of approach and effectiveness.

The solution techniques for the capacitor allocation problem can be classified into four categories: Analytical, Mathematical Programming, Heuristics, and Artificial

Intelligence-based. The next sections outline the published techniques in each category and present their merits and shortcomings.

### 3.3.1 Analytical Methods

All early works of optimal capacitor placement used analytical methods. These algorithms were devised when powerful computing resources were unavailable or expensive. Analytical methods involve the use of calculus to determine the maximum of a capacitor savings function. This savings function has often been given by:

$$S = K_E \Delta E + K_P \Delta P - K_C C, \quad (3.1)$$

where:

$K_E$  is the cost of energy in \$/kWh;

$\Delta E$  is the reduction of energy losses in kWh;

$K_P$  is the cost of peak power in \$/kW;

$\Delta P$  is the reduction of peak power losses in kW;

$K_C$  is the cost of capacitors in \$/kvar

$C$  amount of compensation in kvar.

The pioneers of optimal capacitor placement, Neagle and Samson [17], Cook [18, 19], Schmill [20], Chang [21, 22], and Bae [23], all used analytical approaches to maximize some form of the cost function in Equation (3.1). Although simple closed-form solutions were achieved, these methods were based on unrealistic assumptions of

a feeder with a constant conductor size and uniform loading. It was from this early research that the famous “two-thirds rule” became established. The “two-thirds rule” advocates for maximum loss reduction; a capacitor rated at two-thirds of the peak reactive load should be installed at a position two-thirds of the distance from the source along the total feeder length.

These early analytical methods are easy to understand and implement. Despite, the unrealistic assumptions made by the “two-thirds” rule, some utilities today still implement their capacitor placement program based on this rule [23], and some capacitor manufacturers list this rule in their application guides [24].

To achieve more accurate results, the feeder models were improved. Grainger *et al.* [25, 26], and Salama *et al.* [27, 28] formulated equivalent normalized feeders which considered feeder sections of different conductor sizes and non-uniformly distributed loads. Grainger *et al.* also included the planning of switched capacitors in their algorithms, and further improved their work in capacitors by incorporating voltage regulator placement in subsequent publications [29, 30, and 31]. These latter analytical methods provide realistic modeling of radial distribution feeders, and consider the varying load of distribution systems. To further demonstrate the importance of proper modeling of the distribution feeder and the consideration of the varying load, Grainger *et al.* indicated by example in [25] how the “two-thirds rule” could be grossly inaccurate and result in negative savings.

One drawback of all analytical methods is the modeling of the capacitor placement locations and sizes as continuous variables. As a consequence, the calculated capacitor sizes may not match the available standard sizes and the calculated locations may not coincide with the physical node locations in the distribution system. The results would need to be rounded up or down to the nearest practical value and cause a possible overvoltage situation or a loss savings less than the calculated one. For a simple feeder system with evenly distributed loads, the earlier works provide a rough rule of thumb for capacitor planning. The recent analytical methods of Salama *et al.* [46] and Grainger *et al.* [26] are much more accurate and suitable for distribution systems of considerable sizes, but require detailed distribution system information and more time to implement.

### **3.3.2 Mathematical Programming Methods**

As computing power became more readily available and computer memory less expensive, mathematical programming methods were devised to solve optimization problems. Mathematical programming methods are iterative techniques used to maximize (or minimize) an objective function of decision variables. The values of the decision variables must also satisfy a set of constraints. For optimal capacitor allocation, the savings function would be the objective function and the locations, sizes, number of capacitors, bus voltages, and currents would be the decision variables which must all satisfy operational constraints. Mathematical programming methods allow the use of more elaborate cost functions for the optimal

capacitor placement problem. The objective functions can consider all the voltage and line loading constraints, discrete sizes of capacitors, and physical locations of nodes. Using mathematical programming methods, the capacitor allocation problem can be formulated as follows:

$$\text{MAX } S = K_L \Delta L - K_C C, \quad (3.2)$$

$$\text{subject to : } \Delta V \leq \Delta V_{MAX},$$

where:

$K_L \Delta L$  is the cost savings which may include energy and peak power loss reductions, and released capacity;

$K_C C$  is the installation costs of the capacitors; and,

$\Delta V$  is the change in voltage due to capacitor installation which must not exceed a maximum of  $\Delta V_{MAX}$ .

Duran [32] was the first to use a dynamic programming approach to the capacitor placement problem. The formulation in [32] is simple. It considers only the energy loss reduction and accounts for discrete capacitor sizes. Fawzi *et al.* [33] followed the work of [32] but included the released kVA into the savings function. Ponnaivaikko and Rao [34] used a mathematical method called the method of local variations and further expanded the problem to include the effects of load growth, and switched capacitors for varying load. Similarly, Baran and Wu [35, 36] formulated the capacitor placement problem using mixed integer programming. Baldick and Wu

[37] expanded the work of [35, 36], and used integer quadratic programming to coordinate the optimal operation of capacitors and regulators in a distribution system.

By inspection of all the mathematical programming methods, one can observe that the level of sophistication and the complexity of the models increase in chronological order of their publication time. This progression concurs with the advancement in computing capability. At the present time, powerful computing is relatively inexpensive, and many general numerical optimization packages are available to implement any of the above algorithms. Some of the mathematical programming methods have the advantage of considering feeder node locations and capacitor sizes as discrete variables. This is a definite advantage over analytical methods. However, the data preparation, and interface development for numerical techniques require more time than for analytical methods. One must also determine the convexity of the capacitor placement problem to determine if the results yielded by a mathematical programming technique is a local or global extremum. Furthermore, in formulations that include the released kVA benefits and load growth effects, it may be difficult to assign economic values to such quantities.

### **3.3.3 Heuristic Methods**

Heuristics are rules of thumb that are developed through intuition, experience and judgment. Heuristic rules produce fast and practical strategies which reduce the exhaustive search space and can lead to a solution that is near optimal with confidence.

Methods based on heuristic search techniques have been introduced for distribution system loss reduction by reconfiguration [38, 39]. Abdel-Salam *et al.* [40] proposed a heuristic technique based on the ideas from [38, 39] to identify a section in the distribution system with the highest losses due to reactive load currents and then pinpoint the *sensitive* node in that section having the greatest effect on the system loss reduction. Sizes of capacitors placed on the *sensitive* nodes are then determined by maximizing the power loss reduction from capacitor compensation. Chis *et al.* [41] improved on the work of [40] by determining the *sensitive* nodes that have the greatest impact on loss reduction for the entire distribution system directly, and by optimizing for the capacitor size based on maximizing the net economic savings from both energy and peak power loss reduction. In addition, the method in [41] also accounts for varying loads of the distribution system considered.

Both of the above heuristic methods are intuitive, easy to understand, and simple to implement as compared to analytical and mathematical programming methods. However, the results produced by heuristic algorithms are not guaranteed to be optimal.

### **3.3.4 AI-Based Methods**

The recent popularity of AI has led many researchers to investigate its use for power engineering applications. In particular, Genetic Algorithms (GAs), Simulated Annealing (SA), Expert Systems (ESs), Artificial Neural Networks (ANNs) and Fuzzy Set Theory (FST) have been implemented in the optimal capacitor placement problem.

### **3.3.4.1 Genetic Algorithms**

Genetic algorithms use biological evolution to develop a series of search space points toward an optimal solution. This approach involves coding of the parameter set rather than working with the parameters themselves. GAs operate by selecting a population of the coded parameters with the highest fitness levels (i.e. parameters yielding the best results), and performing a combination of mating, crossover, and mutation operations on them to generate a better set of coded parameters. Genetic algorithms are simple to implement and are capable of locating the global optimal solution.

Boone and Chiang [42] devised a method based on GAs to determine optimal capacitor sizes and locations. The sizes and locations of capacitors are encoded into binary strings and crossover is performed to generate a new population. This problem formulation only considered the costs of the capacitors and the reduction of peak power losses. Sundhararajan and Pahwa [43] also used GAs for the optimal selection of capacitors in distribution systems. However, their work differs from [42] in that they use an elitist strategy; whereby the coded strings chosen for the next generation do not go through mutation or crossover procedures. In addition, this formulation includes the reduction of energy losses which was omitted in [42]. Miu *et al.* [44] revisited the GA formulation in [42], and included additional features of capacitor replacement and control for unbalanced distribution systems.

### **3.3.4.2 Expert Systems**

Expert Systems (ES) or Knowledge-Based Systems (KBS) consist of a collection of rules, facts (knowledge) and an inference engine to perform logical reasoning. The ES concept has been useful for power system problems that require decision-making, empirical judgments or heuristics. Most ESs used in power system engineering applications are for fault diagnosis, planning and scheduling [45].

Salama *et al.* [46] and Laframboise *et al.* [47] developed an ES containing Technical Literature Expertise (TLE) and Human Expertise (HE) for reactive power control of a distribution system. The TLE included the capacitor allocation method was based on the methods of [27, 28] for maximum savings from the reduction of peak power and energy losses. The HE component of the knowledge base contained information to guide the user to perform reactive power control for the planning, operation and expansion stages of distribution systems.

### **3.3.4.3 Simulated Annealing**

Simulated annealing is an iterative optimization algorithm which is based on the annealing of solids. When a material is annealed, it is heated to a high temperature and slowly cooled according to a cooling schedule to reach a desired state. At the highest temperature, particles of the material are arranged in a random formation. As the material is cooled, the particles become organized into a lattice-like structure that is at minimum energy state. For the capacitor allocation problem, a total cost function

is formulated instead of a savings function. Analogous to reaching a minimum energy state of the annealing of solids, Ananthapadmanabha *et al.* [48] used SA to minimize a total cost function given by:

$$T_{loss} = K_P P_{loss} + K_E E_{loss} + K_C C, \quad (3.3)$$

where:

$K_P P_{loss}$  is the cost of peak power losses;

$K_E E_{loss}$  is the cost of energy losses; and,

$K_C C$  is the capacitor installation costs.

#### 3.3.4.4 Artificial Neural Networks

An artificial neural network is the connection of artificial neurons which simulates the nervous system of a human brain. Artificial neural networks are useful for mapping non-linear relationships between inputs and outputs. An ANN typically consists of three types of layers: an input layer, one or more hidden layers, and an output layer. The ANN accepts known input data and minimizes the difference between the known outputs and the generated outputs. The relationship between the inputs and the outputs are embedded as parameters in the hidden layer. Correct output patterns can be generated by the ANN provided that there are enough hidden layers and nodes to encode the input-output pattern, and enough known data to train the ANN. Once an ANN is trained, it can provide very fast results given a set of inputs. Figure 3.1 shows the structure of an ANN.

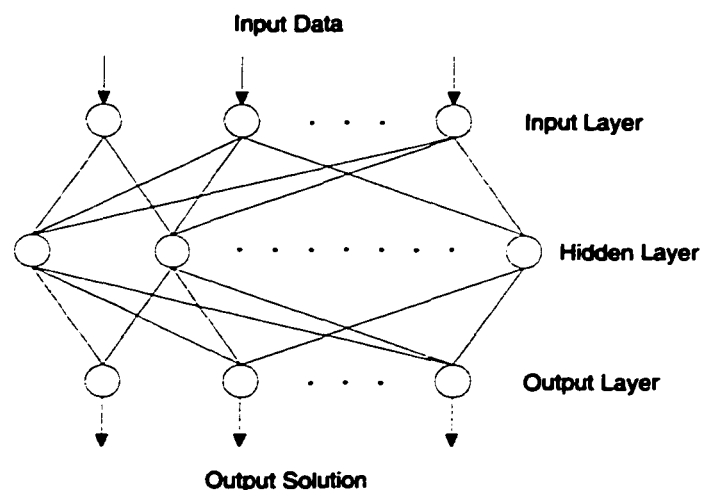

**Figure 3.1: Structure of an Artificial Neural Network**

Santoso and Tan [49] used ANNs for the optimal control of switched capacitors. In their work, two neural networks are used. One network is used to predict the load profile from a set of previous load values obtained from direct measurement at various buses, and a second neural network is used to select the optimal capacitor tap positions based on the load profile as predicted by the first network. The first network is trained with a set of pre-recorded load profiles and the second network is trained to maximize the energy loss reduction for a given load condition. Once both networks are trained, iterative calculations are no longer required and a fast solution for a given set of inputs can be provided.

The algorithm in [49] was tested on a 30-bus test system. To reduce the complexity of the training, the test case was separated into six smaller sub-systems. Thus, six, two-staged ANNs were trained and shown to yield satisfactory results. Although this method was suitable for on-line implementation of the small example

system, it may not be appropriate for much larger realistic distribution systems; since, one may need to partition a large distribution system into many smaller sub-systems. And, as even the authors have acknowledged, the training time required for the neural networks may be immense. Gu and Rizy [50] followed the method of [49] and included an additional functionality of voltage regulator control.

#### **3.3.4.5 Fuzzy Set Theory**

The concept of Fuzzy Set Theory (FST) was introduced by Zadeh [51] in 1965 as a formal tool for dealing with uncertainty and soft modeling. A fuzzy variable is modeled by a membership function which assigns a degree of membership to a set. Usually, this degree of membership varies from zero to one. Chin [52] used FST and assigned three membership functions to describe power loss, bus voltage deviation and harmonic distortion. A decision variable to determine nodes for capacitor placement is then calculated by taking the intersection of the three membership functions for each node in the distribution system. The nodes with the greatest decision values are selected for capacitor installation. No mathematical optimization procedure is given in [52] to calculate capacitor sizes to be placed in the nodes selected by the fuzzy procedure.

#### **3.3.4.6 Summary of AI Methods**

All of the above AI methods can be implemented using commercially available AI development shells or be hardcoded using any programming language with relative

ease. For techniques using GAs, SAs or ANNs, the user may encounter non-convergence problems which can be troublesome to rectify. For on-line applications, ANNs can only be used for a particular load pattern. ANNs would need to be re-trained for every different set of load curves characteristic of the distribution system. However, the use of ESs is better suited for on-line and dynamic applications.

### **3.4 An Assessment of the Available Capacitor Allocation**

#### **Techniques**

Section 3.3 has described Analytical, Mathematical Programming, Heuristic and AI-Based techniques for optimal capacitor allocation. It would be difficult to implement all of the methods to make a performance comparison. However, each of these methods has its own merits. The choice of which method to use is dependent on:

- the problem to be solved;
- the complexity of the problem;
- the accuracy of results desired; and,
- the practicality of implementation.

Once these criteria are determined, the appropriate capacitor allocation technique can be chosen.

### **3.4.1 Capacitor Allocation Problem to be Solved**

The capacitor allocation problem can be separated into three subproblems: Planning, Expansion and Control. Most of the capacitor allocation techniques in the literature address the Planning subproblem. However, many of these techniques can be used for the Expansion subproblem if the predicted load growth and specifications of expanded distribution system are known. The capacitor allocation algorithms mentioned in this chapter that can be used for the Expansion subproblem without any modification are found in [34, 44, 46, 47]. The Control subproblem involves the operation of switched capacitors for the most economic savings while avoiding overvoltages. Again, few techniques are available for the control subproblem [44, 49, 50].

### **3.4.2 Complexity of Problem**

When solving the capacitor placement problem, it must be decided which parameters are to be included into the optimization process. The capacitor savings functions can include the dollar savings from the reduction of energy and peak power losses, the released kVA capacity, and voltage profile improvement. In addition, it must be decided if the varying load is to be considered, which load model to use, and if the inclusion of regulators is desired. There is not one technique that can include all of the parameters listed above. The complexity of the problem also includes the type of distribution system to be considered. Some of the capacitor placement techniques

can only be applied to a single feeder without lateral branches, while others can accommodate radial systems with many lateral sub-feeders, and a few can be used for any distribution system of any topography. Furthermore, the algorithms that can consider many of the parameters require more detailed system data, and tend to be more difficult to implement.

### **3.4.3 Accuracy of Results**

The accuracy of results depends on the modeling of the problem and the optimization method. The more recent analytical methods which use equivalent feeder models and consider the varying load can provide better results than the earlier capacitor placement techniques. Furthermore, some mathematical programming techniques, heuristic and AI techniques consider the discrete sizes and non-linear costs of capacitors which also contribute to better accuracy in the results. The accuracy of the results also depends on the availability of the data.

### **3.4.4 Practicality**

The practicality of the capacitor placement algorithm includes the ease of understanding and implementation of the method. This criterion is the most subjective in the decision of choosing which capacitor allocation method to use. However, this is one of the important criteria to be considered. Some techniques may require a lot of data which is unavailable and others may be oversimplified for the accuracy of results desired.

**Table 3.1 compares the features and capabilities of all the capacitor placement algorithms described in this chapter. The algorithms are classified by their formulation as either Analytical, Mathematical Programming, Heuristic or AI-Based problems, and also by features of the complexity of solution, accuracy, and practical applicability.**

Table 3.1: Comparison of Capacitor Allocation Methods

Energy loss reduction in formulation		◆	◆	◆		◆	◆	◆	◆	◆		◆	◆	◆		◆	◆		
Peak power loss reduction in formulation	◆		◆	◆	◆	◆	◆				◆	◆		◆	◆	◆	◆	◆	
Consideration of varying load				◆◆◆	◆◆◆	◆◆◆	◆◆◆				◆◆◆	◆◆◆	◆◆◆	◆◆◆	◆◆◆	◆◆◆	◆◆◆	◆◆◆	
Capacity release in formulation		◆						◆	◆										
Consideration of discrete capacitor sizes							◆◆			◆◆			◆◆	◆◆	◆◆	◆◆			
Accurate feeder representation					◆◆	◆◆				◆◆	◆◆	◆◆	◆◆	◆◆	◆◆	◆◆	◆◆		
Consideration of physical node location							◆◆			◆◆	◆◆	◆◆	◆◆	◆◆	◆◆	◆◆	◆◆	◆◆	
Voltage constraints considered				♥		♥		♥	♥	♥	♥	♥	♥	♥	♥	♥	♥	♥	
Line loading constraints considered							♥												
Radial feeder					◆◆	◆◆	◆◆	◆◆	◆◆	◆◆	◆◆	◆◆	◆◆	◆◆	◆◆	◆◆	◆◆	◆◆	
Planning / Expansion									◆							◆			
Consideration of switched capacitors		◆	◆			◆			◆	◆					◆				
Regulator inclusion						◆													
Use of load flow										◆◆	◆◆	◆◆	◆◆	◆◆	◆◆	◆◆	◆◆	◆◆	
	Neagle & Samson [17]	Cook [18, 19]	Schmill [20]	Chang [21, 22]	Bae [23]	Salama et al. [27, 29]	Granger et al. [25, 26]	Duran [32]	Fawzi et al. [33]	Ponnarajko & Rao [34]	Baran and Wu [35, 36]	Abdel-Salam et al. [40]	Chis et al. [41]	Boone & Chiang [42]	Sundhararajan & Patwa [43]	Miu et al. [44]	Salama et al. [45, 47]	T. Ananthapadmanabha et al. [48]	Chin [52]
	ANALYTICAL						NUMERICAL				HEURISTIC		ARTIFICIAL INTELLIGENCE						

◆ = Complexity

◆ = Accuracy

♥ = Practicality

### **3.5 Achieving a Complete Capacitor Allocation System**

In order to select a capacitor allocation method to use in its distribution system optimization program, a utility must decide on the appropriate software tools to perform the task. The tools to use depend on the utility's goals and system dependent parameters. The utility's goals may include: loss reduction, voltage enhancement, and/or system expansion. System dependent parameters may include the type and sophistication of SCADA system in use, and topography of the distribution system. In an extensive study of software tools used in real-time power systems, it has been indicated that half of the utilities in the survey were not satisfied with using conventional numerical-based approaches [53]. Dissatisfaction amongst the participating utilities was found with the lack of flexibility in the system modeling and the exclusion of the user's input in the decision-making procedures. Thus, the tools chosen to perform the distribution system enhancement tasks must match the goals of the utility and also have the flexibility of being properly and easily integrated into the existing operating parameters of the distribution system.

The proposed distribution system enhancement technique employs a Fuzzy Expert System (FES) which can solicit information from the user, and a fuzzy optimization procedure that has the flexibility of providing solutions for planning, expansion and operation of distribution systems. Furthermore, some uncertainty or even unavailability of system data can be handled by the use of fuzzy set theory.

### **3.6 Summary**

Many different techniques have been devised to solve the problem of capacitor allocation in distribution systems. This chapter has identified and classified many of the published capacitor placement algorithms in the literature. This information serves as a basis of features and capabilities that are desirable for a distribution system performance enhancement solution. The next chapter will provide a review of fuzzy set theory and its application to power systems. Furthermore, its content will also aid in the understanding of the advantages of this thesis' proposed distribution system enhancement procedure.

## **4 Applications of Fuzzy Set Theory in Power Systems**

### **4.1 Introduction**

As in many engineering disciplines, power systems engineers may encounter many problems involving information that is uncertain, inexact, imprecise or even unavailable. Furthermore, it is possible that the solution of these problems may involve human thinking and reasoning that are based on concepts originating from similar experiences and/or intuition rather than require the more traditional methods of solving detailed engineering models representing well-behaved systems. Such real-world problems cannot be modeled using systems based upon classical set theory. However, fuzzy set theory (FST) was introduced by Zadeh [51] as a formal means to represent uncertainty and vagueness mathematically. Fuzzy set theory also allows for

the inclusion of heuristics or qualitative knowledge into the solution of a problem for better possible answers. The next sections provide a review of FST and a survey of the application of FST to power systems.

## 4.2 A Brief Review of Fuzzy Set Theory

Fuzziness occurs when the bounds on a piece of information are not exactly defined. Therefore, a fuzzy variable or element is represented by a membership function which indicates its varying degree of belonging to a set. This degree of membership can vary between zero, signifying no membership to the set, and unity, suggesting full membership to the set. In contrast to classical set theory, an element can only be assigned a binary value indicating null or full membership to a set. In formal terms, a fuzzy set  $A$  in a universe of discourse  $U$  is represented by a membership function:

$$\mu_A : U \rightarrow [0,1] \quad (4.1)$$

which associates with each element  $x \in U$ , a number  $\mu_A(x)$  in the interval  $[0,1]$ . Also known as a possibility distribution function,  $\mu_A(x)$  is interpreted as the grade of membership of  $x$  in the fuzzy set  $A$ .

To illustrate the concepts of FST, consider the following example: In describing distribution loads, the adjectives, *light*, *medium* or *heavy* are often used. However, there is no single quantitative value which can define a *heavy* load. If the load is 1 p.u., the load is definitely *heavy*. However, if the load is 0.75 p.u., the load

may be considered as *medium*, or depending on the context it is considered, the load of 0.75 p.u. may also be possibly *heavy*. In classical set theory, where the mapping of an element to a set is clearly described, a load value of 0.75 p.u. must either be medium or heavy. But, using FST, the distribution load can be represented as a fuzzy variable allowing it to have a varying degree of both *medium* and *high*. Thus, considering the distribution load as a fuzzy variable and the linguistic terms of *light*, *medium*, and *heavy* as fuzzy set values, appropriate membership functions are constructed in Figure 4.1.

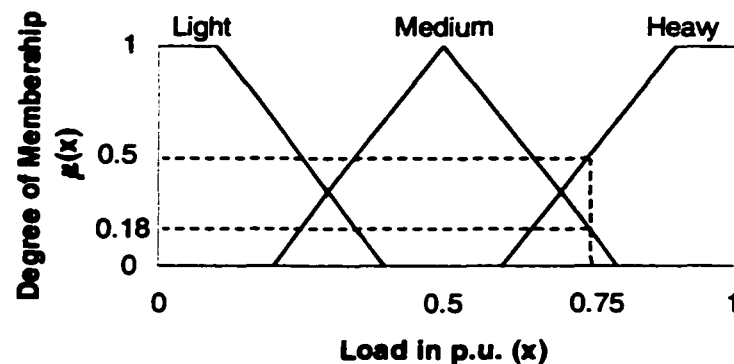

Figure 4.1: Membership Functions for *Light*, *Medium*, and *Heavy* Loads

For the particular case of a load being 0.75 p.u., it may be considered as *heavy* with a degree of 0.5 and also *medium* with a degree of 0.18.

A concern for the development of fuzzy systems is the assignment of appropriate membership functions. Construction of membership functions can be based on intuition, human experience, rank ordering or probabilistic methods [54]. Some studies have shown that the shape of the membership functions and the choice

of the membership degrees in the  $[0,1]$  interval does not change the overall solution of the system in question [55]. What is important is the ordering of the fuzzy sets in the system. In the previous example, note that the fuzzy set of *Light* is before *Medium*, which precedes *Heavy*. This is the only order that makes sense. Finally, another justification of these non-precise methods of constructing membership functions is that the data available is already vague or imprecise. Thus, as long as the data is more or less satisfactory, it can be expected that in the true nature of fuzzy systems, the membership functions are also satisfactory for solving the problem.

### **4.3 Applications of Fuzzy Set Theory to Power Systems**

The principles of FST were first introduced by Zadeh in 1965 [51]. Yet, it was not until the late 1970s that concepts of FST were first applied to power system problems. Furthermore, a review of power system applications indicates that FST has only been employed for a few problems. Some of these applications include:

- load flow analysis and optimal power flow;
- load forecasting and planning;
- reactive power and voltage control; and,
- fault detection.

The following subsections review the use of FST in each of the above applications. It should also be noted that the following subsections are not a complete survey of all published power system applications utilizing FST. The goal of these

subsections is only to highlight the benefits of FST applied to power system problems. At the end of this chapter, it should be evident of how FST is useful for a distribution system enhancement program.

### 4.3.1 Load Flow Analysis and Optimal Power Flow

Miranda and Matos [56] first introduced the idea of a fuzzy load flow in 1990 citing that loads are neither deterministic nor probabilistic, but are better described in a qualitative or linguistic manner. They provide examples such as: “The load in bus 10 will be *approximately* 12 MW,” and “Load in bus 5 is *mainly* of industrial type.” To represent the uncertainty in the loads and generation, Miranda and Matos assigned trapezoidal-shaped membership functions for each variable.

The work in [56] was further extended by Miranda and Saraiva [57] to a fuzzy optimal power flow (OPF) problem. This fuzzy OPF problem was formulated to minimize the uncertain cost of energy with operational and security constraints:

$$\text{minimize } \tilde{Z} = \sum_{i=1}^n a_i \tilde{G}_i, \quad (4.2)$$

$$\text{subject to: } \sum_{i=1}^n \tilde{G}_i = \tilde{L}, \quad (4.3)$$

$$P_j^{\min} < \tilde{P}_j < P_j^{\max}, \quad (4.4)$$

where:

$a_i$  is the incremental cost of generator  $i$  of  $n$  total generators;

$\tilde{G}_i$  is the fuzzy generation at bus  $i$ ;

$\tilde{L}$  is the total possible load distribution;

$\tilde{P}_j$  is the fuzzy power flow on branch  $j$ ; and,

$P_j^{\min}$ , and  $P_j^{\max}$  are the maximum and minimum admissible power flow in branch  $j$ .

In order to solve the objective function expressed by Equation (4.2), a DC load flow was used. The solution of the fuzzy OPF yielded membership functions for possible generations at each generation bus. These fuzzy solutions would be the equivalent of analyzing a whole set of load scenarios at one time.

### **4.3.2 Load Forecasting and Planning**

Load forecasting can either be for the short-term or for the long-term. As the name implies, short-term load forecasting involves predicting the load for the near future. Short-term load forecasting is usually performed on an hourly basis and the forecasts are used by utilities to determine the amount of generation to dispatch or cut in order to match the demand. However, in long-term load forecasting, the prediction of the load is over a much longer time horizon in the range of 5 to 30 years. Distribution system planning is done after long-term load forecasting when it is found that the current generation and transmission system is insufficient to support the increased load of the future. Fuzzy set theory has been applied to both short-term load forecasting and planning.

#### 4.3.2.1 Short-Term Load Forecasting

Many traditional load forecasting techniques employ statistical methods to predict future loads. For short-term load forecasting problems, statistical methods rely heavily on weather variables. In order to deal with the uncertainties in weather variables and statistical models, Hsu and Kuo [58] proposed the use of FST for short-term load forecasting.

In this short-term load forecasting technique, hourly forecasts are first calculated using a conventional statistical method. The forecasts are then corrected using a Fuzzy Expert System (FES). The inputs to the FES include:

- forecasted hourly loads;
- root mean square errors between the actual load and previous hourly load forecasts;
- an assessment from the operator as to whether the previously predicted temperatures have been *much lower*, *lower*, *close*, *higher*, or *much higher*; and,
- the operator's intuition as to whether he is *quite confident*, *confident*, or *not confident* of the predicted hourly loads.

The errors between the actual load and previous hourly load forecasts are used to create a membership function representing the fuzzy adjustment for future loads predicted. Another set of membership functions representing the operator's assessment of the previously predicted temperatures are also constructed. Using the fuzzy adjustment and the operator's linguistic assessment of the previously predicted

temperatures, the FES inference mechanism calculates a fuzzy adjustment for future hourly load forecasts. Finally, the operator's level of being *very confident*, *confident* or *not confident* are used to further hedge the fuzzy adjustment before it is actually applied to the future hourly load forecasts.

#### **4.3.2.2 Power System Planning**

Power system planning involves designing or expanding power systems for anticipated future load growth under different possible scenarios. As in short-term load forecasting, there are also uncertainties inherent in planning. Saraiva *et al.* [59] proposed the use of FST for power system expansion to address the possible uncertainties in the predicted loads. In this planning procedure, the predicted future loads are represented by membership functions. Then, using these fuzzy loads, the OPF strategy as outlined in [56, 57] by V. Miranda *et al.* are used to assess the merits of alternative system designs. The solution to the fuzzy OPF provides a possible range of operating limits for future generation and also possible loading limits on feeders.

#### **4.3.3 Reactive Power and Voltage Control**

Proper reactive power and voltage control is extremely important in maintaining the security of any power system. Yokoyama *et al.* [60] have noted that many traditional reactive power and voltage control systems have been limited in success because they require a complete matching of inputs to predetermined conditions in order to function effectively. They proposed a simple VAr/voltage

control algorithm based on one simple rule:

**If** the voltage of a load bus violates the operational limit,  
**And** a controller is available for effective voltage control by adjusting its output,  
**And** there is adequate margin of output adjustment to offset the voltage violation,  
**Then** adjust the output of the controller.

In the above rule, the voltage operational limits are described as either *high* or *low*, the margin of output as *raise* or *lower*, and the control action *plus* or *negative*. Each of these variables described by linguistic terms are represented by fuzzy membership functions. This approximate reasoning is carried out each time a load flow analysis identifies a VAR/voltage problem. The control action suggested by the above fuzzy rule is given in linguistic format to the control room operator to interpret.

#### **4.3.4 Power System Protection**

Current fault detection algorithms are able to ascertain the occurrence of a fault in a power system when numerical results are above a certain threshold. In cases where the numbers are close to the threshold, experienced experts may interpret these results as a *probable* fault. However, they will also likely fail to state how *probable* the fault may be. To resolve this problem, Kim and Russell [61] proposed a fuzzy decision-making system for fault detection. This fuzzy decision-making system is essentially a FES taking a fuzzy set of confidence indices: FS (Sure Fault), FM (Medium Fault), SW (Switching), NM (Normal Medium), or N (Normal) as inputs and providing an output status of: (FLT) Fault, (WRG) Warning, or (NRL) Normal.

The confidence indices are represented as trapezoidal membership functions which can further be shifted depending on:

- ground composition as: RK (Rock), SN (Sand), or SO (Sod);
- ground moisture as: DV (Very Dry), DR (Dry), WT (Wet), WV (Very Wet);
- feeder noise level as: NN (No Noise), NL (Low Noise), NM (Medium Noise), or NH (High Noise); and,
- capacitor bank size on feeder as: BN (No Bank), BS (Small Bank), or BL (Large Bank).

Once all the inputs are entered into the fuzzy decision-making system, a decision rule matrix is used to determine the appropriate output. This method of fuzzy decision-making provided fault diagnosis with linguistic terms instead of a numerical value that must be compared to a crisp threshold.

#### **4.4 Summary**

A brief review of FST and its application to power system problems has indicated many of its merits. To summarize, use of FST offers the following advantages:

- uncertainty in the knowledge of the system can be represented by fuzzy variables;
- linguistic variables can be employed to integrate heuristics; and,
- process knowledge expressible in qualitative terms can be included for the problem solution.

In all the described power system problems using FST, it can also be seen that the models presented were efficiently represented by fuzzy models. This concurs with Zadeh's principle of incompatibility "that as systems become more complex, it becomes increasingly difficult to make mathematical statements about them that are meaningful and precise" [62].

This chapter has provided an appreciation of FST and its application to power systems. The next chapter explains the fundamental ideas of the proposed distribution system enhancement program using concepts of FST.

## **5 Objectives of Proposed Method**

### **5.1 Introduction**

So far, the previous chapters have identified capacitor placement as an effective means of loss reduction. Furthermore, the concepts of FST have been introduced and its merits for use in power system applications have been justified.

This chapter describes the objectives of the thesis. This thesis details a distribution system loss reduction and performance enhancement algorithm using capacitor placement and control as a primary method for loss reduction. The main objectives of the proposed method aim to achieve efficient management and operation of the distribution system in terms of reducing losses while maintaining operational constraints of the system. In addition, the proposed method also:

- accounts for uncertainty in system data;
- addresses the varying loads of the system;

- handles the multi-objective and multi-constraint nature of problem;
- includes utility standards and conforms with standard operating procedures;
- has an user-interactive interface; and,
- can be easily integrated into any utility's existing SCADA system.

This distribution system enhancement scheme contains two main modules for planning and operation of the distribution system. The next sections in this chapter provide overviews of these modules.

## **5.2 Outline of Solution Strategy**

The framework of the proposed method is detailed in Figure 5.1. The scheme of this system initializes by first performing a load flow of the distribution system using current SCADA and/or database load information. Once, voltages, currents, and losses are calculated, the user is asked whether a planning or control operation is desired. If a planning action is selected, the process continues by using the planning module to provide a capacitor placement solution for the distribution system. This solution is validated by another load flow, and presented for implementation. If a control action is selected, it is assumed that capacitors are already in place and the control module provides a capacitor switching scheme or a tap setting schedule. The solution is also validated and approved by the distribution engineer before the action is applied.

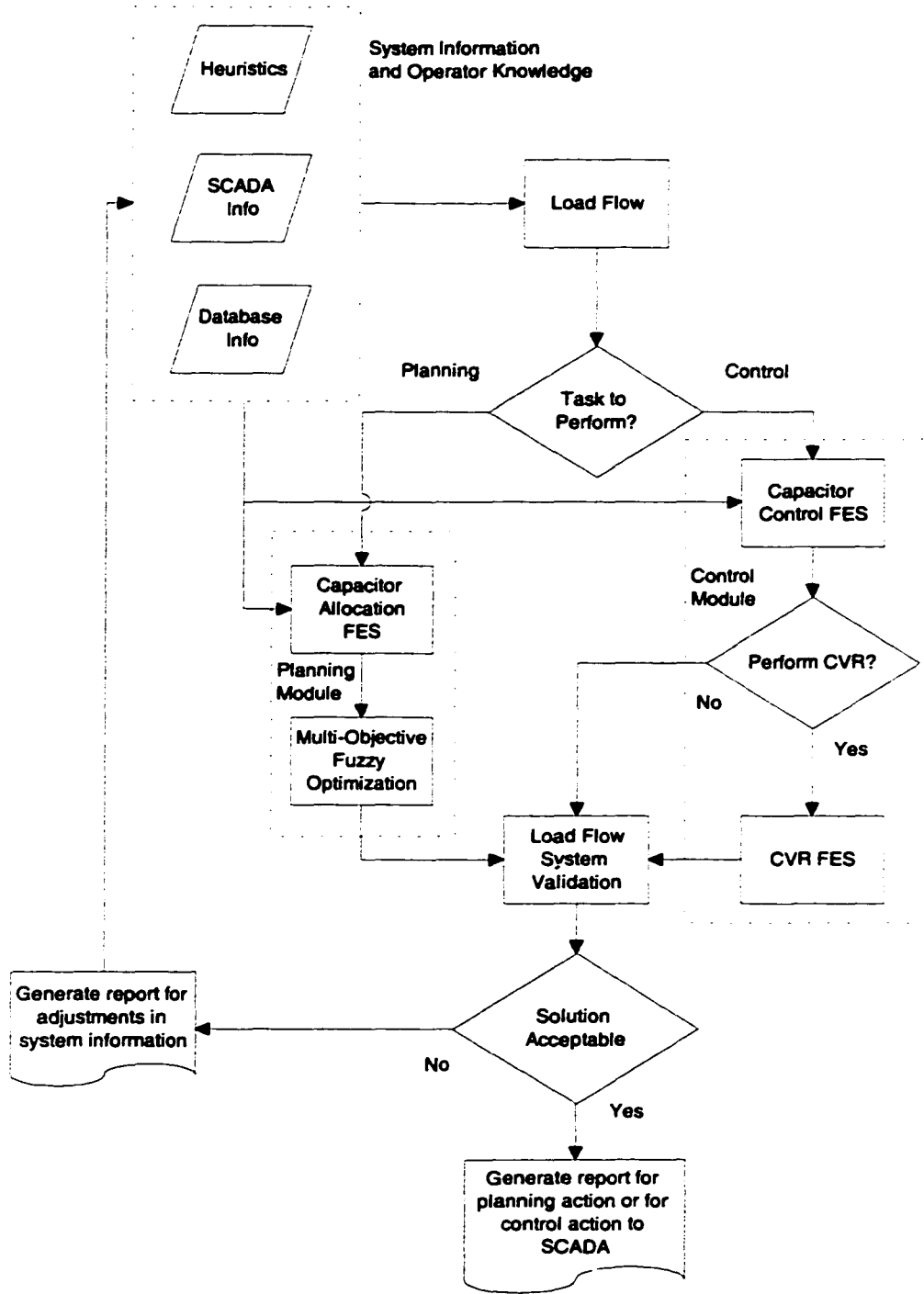

Figure 5.1: Flow of Information

The core of the proposed method of enhancing distribution system performance lies in the planning and control modules while the other modules serve as input or reporting functions of the complete system.

### **5.2.1 Load Flow Models**

Proper modeling of loads is paramount for calculation of losses in a distribution system. Distribution load models can be represented as constant power, constant current, constant impedance or some mixture of the three. The traditional load flows methods of Newton-Raphson and Gauss-Seidel consider a constant power load model and do not consider the voltage dependence of most distribution system loads. The load flow method used in the proposed method is based on an adaptation of ladder network theory of linear systems. This load flow method is also capable of considering different load models. Details of this load flow method are further discussed in Chapter 8.

### **5.2.2 Planning Module**

The main functions of the planning module are to determine the most suitable locations, sizes and number of capacitors, and switched capacitors to place in the distribution for maximum reduction of losses. Whether capacitor planning is for an existing distribution system or for a new distribution system design that is to be built, the load data used by the algorithm is not completely certain. An assumption that the load data is absolutely certain is the one major drawback of all the capacitor placement

methods reviewed in Chapter 3. For the proposed distribution system enhancement program, the planning module utilizes a FES and multi-objective fuzzy optimization to allow for the inclusion of technical heuristics, utility standards, and also for the consideration of inexact or unavailable load data. Chapter 6 discusses this module in detail.

### **5.2.3 Control Module**

Operation of a distribution system requires timely information of the system status, and a coordination of the system operator's expert judgement on proper control actions. The control module in the proposed method determines capacitor switching schemes, and substation transformer tap settings for CVR. This module is designed such that the use of data from the SCADA system and any operator inputs are facilitated. Again a FES aids in the process of load model selection, CVR policy, firing of switching rules and any resolution of decision conflicts which may occur. Chapter 7 describes this module in detail.

## **5.3 Summary**

Following a review of the shortcomings of previous methods of distribution system improvement and the advantages of employing FST principles to power system applications, this chapter has described a proposed comprehensive distribution system enhancement scheme that alleviates the discussed deficiencies. The use of FST is

applied to achieve the goals of the proposed method. Mostly, FST is applied to resolve issues of uncertain data, and the integration of human expertise and decision making into the system optimization process. The functionality and the advantages of the modules in this proposed system become evidently clear as they are described in detail with examples in the next chapters.

## **6 Capacitor Planning**

### **6.1 Introduction**

The capacitor planning module is one of the core components of the proposed distribution system enhancement scheme. The capacitor planning module uses fuzzy approximate reasoning to determine suitable candidate nodes in the distribution system for capacitor placement. To determine the sizes of the capacitors, a multi-objective optimization method is then used.

### **6.2 Capacitor Location Selection by Approximate**

#### **Reasoning**

As mentioned in Chapter 3, Salama *et al.* [46, 47] built an expert system to optimally allocate capacitors in distribution system. However, as Chapter 4 has

outlined, human thinking and knowledge often involve subjective, vague, and uncertain information. Conventional knowledge-based systems contain a set of rules which assign appropriate actions for given specific conditions. These rules can only be activated when the inputs completely match the predefined circumstances. Unfortunately, these expert systems fail in environments where there is uncertainty or vagueness in the inputs. Approximate reason by the use of a FES alleviates such problems.

For the capacitor placement problem, approximate reasoning is employed in this manner: when losses and voltages levels of a distribution system are studied, an experienced planning engineer can choose locations for capacitor installations which are probably *highly suitable*. For example: it is intuitive that a section in a distribution system feeder with *high* losses and *low* voltage is *highly* ideal for placement of capacitors; whereas a *low* loss section with good voltage is not. Note that the terms, *high* and *low* are linguistic descriptors which cannot be used to define rules in a conventional ES. Following the idea of the above example, an entire set of fuzzy rules has been created to determine suitable capacitor locations in a distribution system. These fuzzy rules are discussed in the next sections.

### **6.2.1 Framework of Capacitor Allocation Approach**

The entire framework of this approach to solve the capacitor allocation problem includes the use of numerical procedures which are coupled to the FES. First, a load flow program calculates the power loss reduction by compensating the

total reactive load current at every node of the distribution system. The loss reductions are then linearly normalised into a  $[0, 1]$  range with the largest loss reduction having a value of 1 and the smallest one having a value of 0. These power loss reduction indices along with the per-unit node voltages are the inputs into the FES which determines the node most suitable for capacitor installation. Finally, a multi-objective optimization technique is used to determine the optimal size of capacitor to be placed at the chosen node for the most economic savings. Figure 6.1 illustrates the flow of data through the individual components of this system.

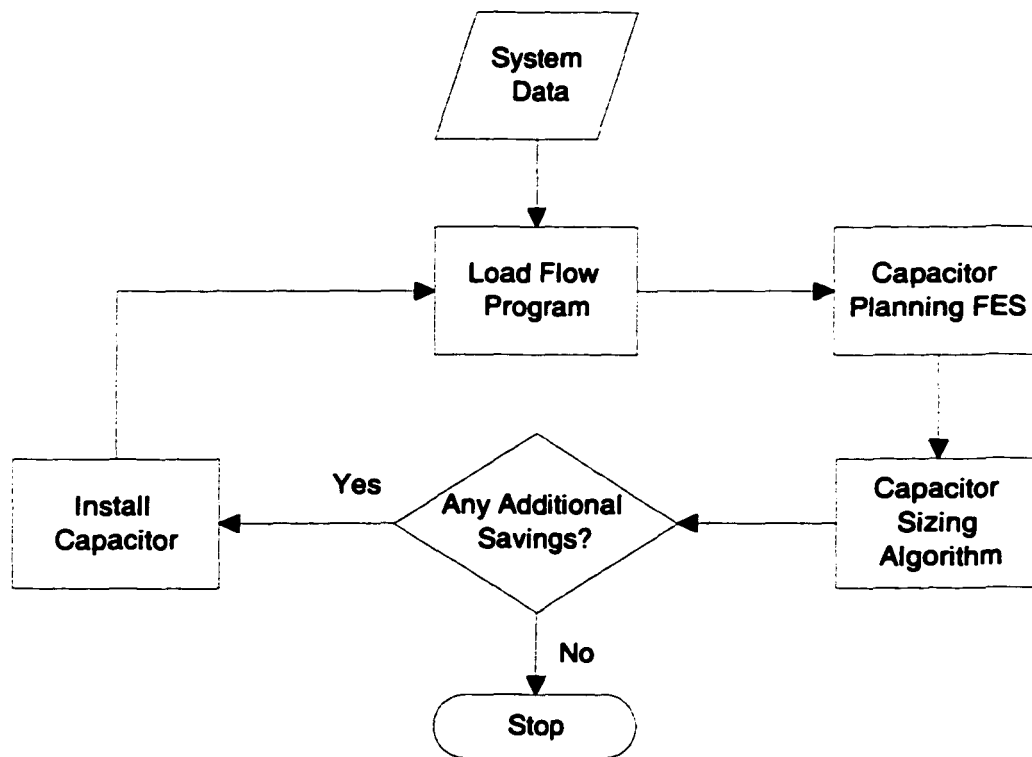

Figure 6.1: Framework of Approach

This capacitor allocation procedure is repeated until no additional savings from the installation of capacitors are achieved. The capacitor sizing procedure also takes into account of the discrete nature of capacitor sizes and uses a piecewise cost function for capacitors. The next subsections establish the rules in the capacitor FES and explain the mechanics of the fuzzy inferencing.

### **6.2.2 Fuzzy Rules for Location of Suitable Capacitor Installations**

The FES in the planning module contains a set of rules which are developed from qualitative descriptions. In a FES, rules may be fired with some degree using fuzzy inferencing; whereas, in a conventional ES, a rule is either fired or not fired. For the capacitor allocation problem, rules are defined to determine the suitability of a node for capacitor installation. Such rules are expressed in the following form:

**If** premise (antecedent), **Then** conclusion (consequent).

For determining the suitability of capacitor placement at a particular node, a set of multiple-antecedent fuzzy rules have been established. The inputs to the rules are the voltage and power loss indices, and the output consequent is the suitability of capacitor placement. The rules are summarized in the fuzzy decision matrix in Table 6.1. The consequents of the rules are in the shaded part of the matrix.

The fuzzy variables, power loss reduction, voltage, and capacitor placement suitability are described by the fuzzy terms: *high*, *high-medium/normal*, *medium/normal*, *low-medium/normal* or *low*. These fuzzy variables described by

linguistic terms are represented by membership functions. The membership functions are graphically shown in Figures 6.2-6.4.

Table 6.1: Fuzzy Decision Matrix

AND		Voltage				
		Low	Low – Normal	Normal	High – Normal	High
Power Loss Index	Low	Low – Medium	Low – Medium	Low	Low	Low
	Low – Medium	Medium	Low – Medium	Low – Medium	Low	Low
	Medium	High – Medium	Medium	Low – Medium	Low	Low
	High – Medium	High – Medium	High – Medium	Medium	Low – Medium	Low
	High	High	High – Medium	Medium	Low – Medium	Low – Medium

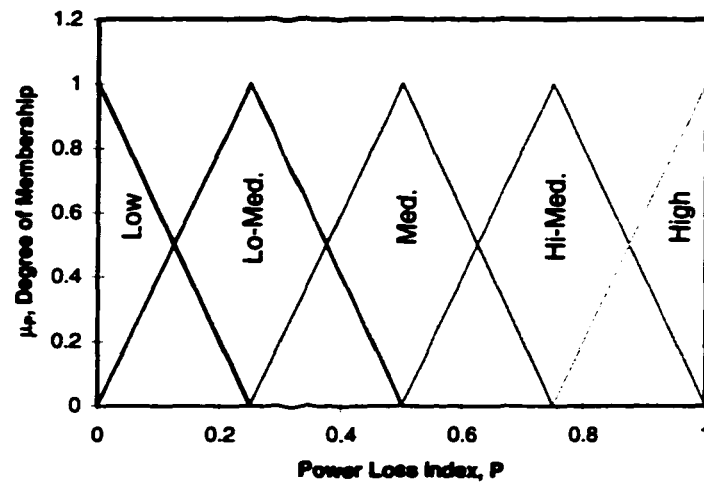

Figure 6.2: Membership Functions for Power Loss Index

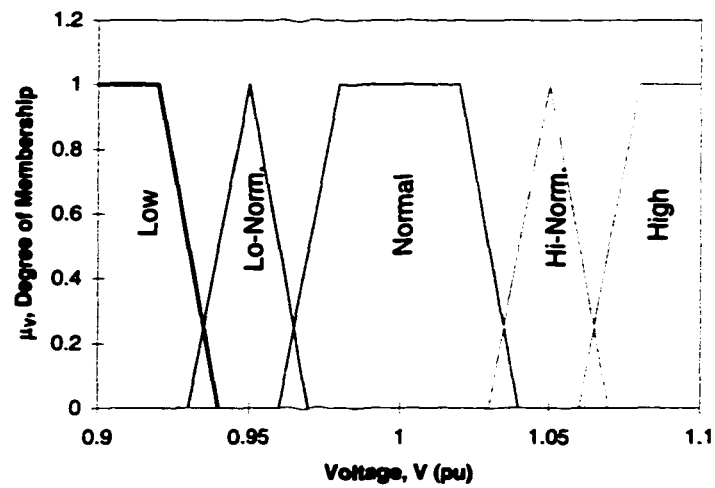

Figure 6.3: Membership Functions for Voltage

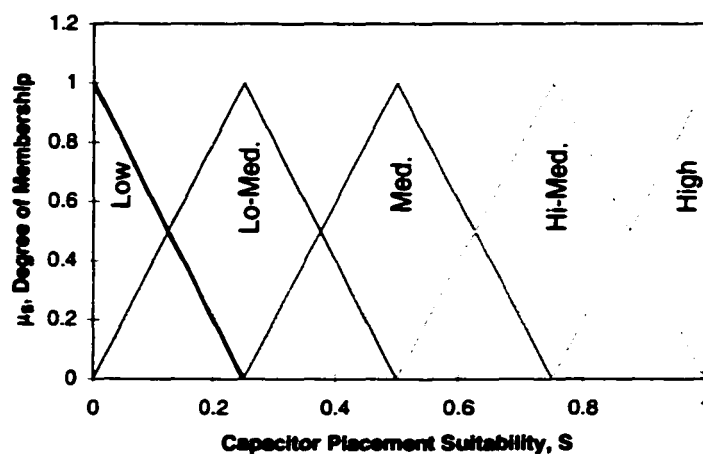

Figure 6.4: Membership Functions for Capacitor Placement Suitability

The construction of the membership functions for the power loss index and the capacitor placement suitability have been created based on rank ordering. Since, in this application of capacitor placement, the interest lies in the ranking of the nodes which are the most suitable for capacitor placement. The membership functions for describing the voltage have been created based on Ontario Hydro Standards of acceptable operating voltage ranges for distribution systems [63]. In the Ontario Hydro Standard, distribution system voltages in the range from 0.96 to 1.04 p.u. are considered favourable. And, voltages dipping as low as 0.93 and rising as high as 1.07 are tolerable for brief moments. Any other voltages outside of that range is extreme and unacceptable. By inspecting Figure 6.5, one can see how the voltage membership functions have been partitioned.

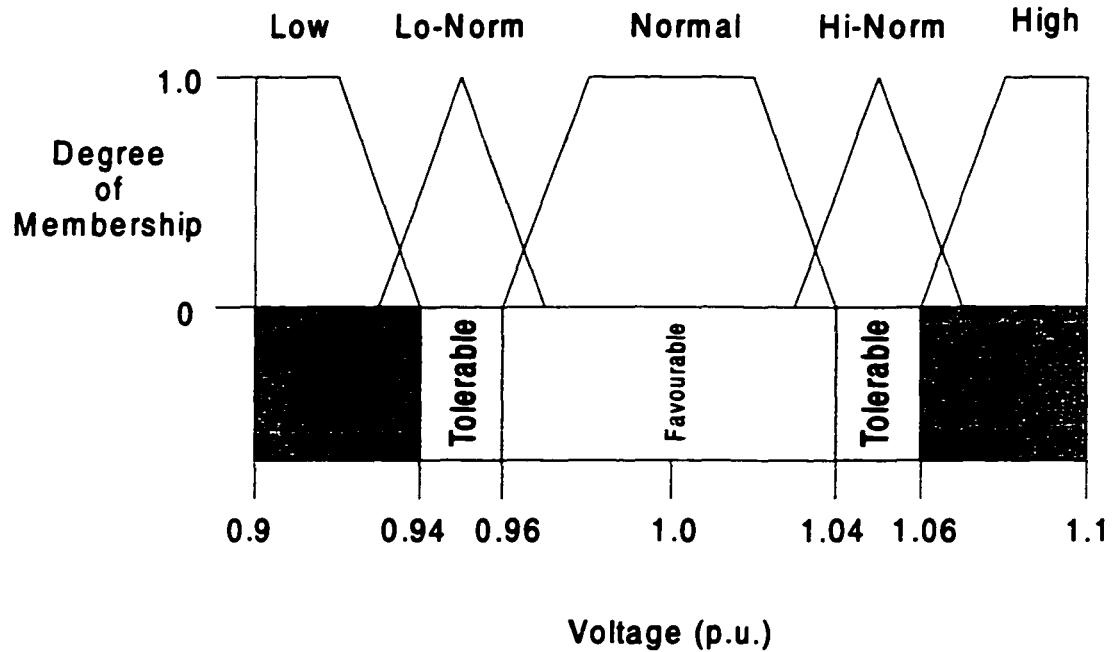

Figure 6.5: Partitioning of Voltage Membership Functions

### 6.2.3 Fuzzy Inferencing and Defuzzification Techniques

After the FES receives inputs from the load flow program, several rules may fire with some degree of membership. The fuzzy inferencing performed in this system is executed by FuzzyCLIPS [64]. FuzzyCLIPS is a fuzzy expert system shell developed for the MS Windows platform. An example of the coding of the fuzzy membership functions and rules are shown in Figures 6.6 and 6.7. Especially note the simplicity of the rule base descriptions.

```

:: voltage membership function definition
(deftemplate voltage
  0 1.5 pu
  ((low (0.92 1) (0.94 0))
   (lo_norm (0.93 0) (0.95 1) (0.97 0))
   (normal (0.96 0) (0.98 1) (1.02 1) (1.04 0))
   (hi_norm (1.03 0) (1.05 1) (1.07 0))
   (high (1.06 0) (1.08 1)))
)

:: power loss membership function
(deftemplate powerloss
  -0.1 1.1
  ((low (0.00 1) (0.25 0))
   (lo_med (0.00 0) (0.25 1) (0.50 0))
   (medium (0.25 0) (0.50 1) (0.75 0))
   (hi_med (0.50 0) (0.75 1) (1.00 0))
   (high (0.75 0) (1.00 1)))
)

:: capacitor placement suitability index
(deftemplate suitability
  0 1
  ((low (0.00 1) (0.25 0))
   (lo_med (0.00 0) (0.25 1) (0.50 0))
   (medium (0.25 0) (0.50 1) (0.75 0))
   (hi_med (0.50 0) (0.75 1) (1.00 0))
   (high (0.75 0) (1.00 1)))
)

```

Figure 6.6: Definition of Fuzzy Membership Functions

```

:: rule definitions
(defrule pl1
  (and (powerloss low)
        (voltage low))
  =>
  (assert (suitability low))
)
(defrule pm1
  (and (powerloss medium)
        (voltage low))
  =>
  (assert (suitability medium))
)
(defrule ph1
  (and (powerloss high)
        (voltage low))
  =>
  (assert (suitability high))
)

```

Figure 6.7: Fuzzy Rule Definitions

The fuzzy inferencing methods used by FuzzyCLIPS are based on the Mamdani [65] max-min and max-prod implication methods of inference. These methods determine the aggregated output from a set of triggered rules. The max-min method involves truncating the consequent membership function of each fired rule at the minimum membership value of all the antecedents. A final aggregated membership function is achieved by taking the union of all the truncated consequent membership functions of the fired rules. For the capacitor allocation problem, the

resulting capacitor placement suitability membership function,  $\mu_S$  of node  $i$  for  $k$  fired rules is given by:

$$\mu_S(i) = \max_k[\min[\mu_P(i), \mu_V(i)]], \quad (6.1)$$

where  $\mu_P$  and  $\mu_V$  are the membership functions of the power loss index and voltage level, respectively.

For the max-prod implication method of inference, the consequent membership function of each fired rule are scaled to the minimum membership value of all the antecedents. Similarly, the final aggregated membership function is the result of the union of all the scaled consequent membership functions of the fired rules. By this inference method, the capacitor suitability membership function,  $\mu_S$  of node  $i$  for  $k$  fired rules is given by:

$$\mu_S(i) = \max_k[\mu_P(i) \cdot \mu_V(i)]. \quad (6.2)$$

Once the suitability membership function of a node is calculated, it must be defuzzified in order to determine the node's suitability ranking. The centroid method of defuzzification has been chosen. This method of defuzzification finds the centre of area of the membership function. Thus, the capacitor placement suitability index is determined by:

$$S = \frac{\int \mu_S(z) \cdot z dz}{\int \mu_S(z) dz} \quad (6.3)$$

For this capacitor placement application, the choice of inference technique or defuzzification method is not an issue since it is the *ordering* of the suitability of the nodes that is important. The defuzzified values of suitability of the nodes will be different by using the various inferencing and defuzzification techniques, but the order of the nodes remains the same regardless of the inferencing and defuzzification techniques used.

## **6.3 Capacitor Sizing**

Once a suitable capacitor location is found using the FES, a multi-objective fuzzy optimization method is used to determine the optimal capacitor size while accounting for the varying nature of the distribution loads and the operational constraints of the system. In this section, multi-objective fuzzy optimization is first described, and then its application to capacitor sizing is detailed.

### **6.3.1 Multi-Objective Fuzzy Optimization**

Similar to other engineering disciplines, power systems engineers encounter many problems that may involve conflicting objectives and constraints. The methods for multi-objective optimization are well established in the literature. Such conventional optimization methods assume that the objectives are well defined, the constraints confine to crisp boundaries, and all the data is precisely known. However, in real-life applications, it is often difficult to develop a precise formulation of the

problem. There may also be the dilemma of evaluating the relative importance between the objectives of the problem to solve. Furthermore, it is possible that the data required to solve the problem are poorly defined or even not known at all. Thus, by applying FST to multi-objective optimization, such real-life problems can be properly solved. In multi-objective fuzzy optimization, satisfaction of the objectives and the constraints is achieved by maximizing the degree of membership of each fuzzy objective and constraint. Each of the fuzzy objectives and the fuzzy constraints are characterized by membership functions. For example, a multi-objective problem with  $k$  objectives and  $p$  constraints is defined as follows:

$$\text{maximise } F(X) = \{f_1(X), f_2(X), \dots, f_k(X)\}^T \quad (6.4)$$

$$\text{subject to: } g_j(X) \leq u_j, j = 1, 2, \dots, m, \quad (6.5)$$

$$g_j(X) \geq l_j, j = m + 1, \dots, p, \quad (6.6)$$

where:

$F(X)$  is a vector of objective functions;

$X^T = (x_1, x_2, \dots, x_n)$  is the design function;

$g_j(X)$  is the  $j$ th constraint function; and,

$u_j$  and  $l_j$  are the respective upper and lower limits for the  $j$ th constraint.

If fuzzy information is involved with multi-objective problem of Equation (6.4), the formulation of the problem involves defining membership functions for the objectives and the constraints. Thus, the membership functions of the fuzzy objectives are defined as:

$$\mu_{f_i}(X) = \begin{cases} 1, & f_i(X) > M_i, \\ \frac{M_i - f_i(X)}{M_i - m_i}, & m_i \leq f_i(X) \leq M_i, \\ 0, & f_i(X) < m_i, \end{cases} \quad (6.7)$$

where:

$$m_i = \min f_i(X); \text{ and,}$$

$$M_i = \max f_i(X).$$

By inspection of Equation (6.5),  $M_i$ , and  $m_i$  are the respective maximum and minimum of the  $i$ th single-objective function. Hence, for each objective membership function, membership values closest to 1 indicate the higher satisfaction of that objective achieved.

For fuzzy constraints, the membership functions are defined as:

$$\mu_{C_j}(X) = \begin{cases} 1, & g_j(X) < u_j, \\ \frac{(u_j + d_j) - g_j(X)}{d_j}, & u_j \geq g_j(X) \geq u_j + d_j, \\ 0, & g_j(X) > u_j + d_j, \end{cases} \quad (6.8)$$

$j = 1, 2, \dots, m,$

$$\mu_{C_j}(X) = \begin{cases} 1, & g_j(X) > l_j, \\ \frac{g_j(X) - (u_j - d_j)}{d_j}, & l_j - d_j \geq g_j(X) \geq l_j, \\ 0, & g_j(X) < l_j - d_j, \end{cases} \quad (6.9)$$

$j = m + 1, \dots, p,$

where  $d_j$  is the tolerance of the constraint  $j$ . The values of  $d_j$  relax the constraints and allow for further possible improvements of the objectives.

Once all the membership functions of the objectives and the constraints are defined, the multi-objective fuzzy optimization problem is converted into a single

objective optimization problem by maximizing the product decision of the membership functions:

$$\text{maximize } \mu_D(X) = \left[ \prod_{i=1}^k \mu_{f_i}(X) \cdot \prod_{j=1}^p \mu_{C_j}(X) \right]^{1/(k+p)} \quad (6.10)$$

$$\text{subject to: } g_j(X) \leq u_j + d_j, \quad (6.11)$$

$$g_j(X) \geq l_j - d_j. \quad (6.12)$$

By maximizing Equation (6.10), the greatest satisfaction of all the objectives and constraints is obtained. In the next section, this multi-objective fuzzy optimization technique is applied to the capacitor allocation problem while considering the varying nature of the loads.

### 6.3.2 Capacitor Sizing Using Multi-Objective Fuzzy Optimization

Capacitor allocation in distribution systems involves finding the maximum net economic savings from peak power loss reductions and energy loss reductions for all system loading conditions. The placement of the capacitors must also not result in any feeder overvoltages. This is a multi-objective problem that can be solved using a fuzzy approach.

To account for varying loads in the system, the daily load curve is partitioned into three time periods, (i.e.  $T1 = 00:00 - 08:00$ ,  $T2 = 08:00 - 16:00$ ,  $T3 = 16:00 - 24:00$ ). For, the sake of demonstrating the concepts of this method, these three time periods of  $T1$ ,  $T2$ , and  $T3$  have been chosen. In practice, the daily load curve can be

partitioned in to more than three time periods if desired. Once, the partitions of the load curve have been made, the load factors for the different periods of the day are calculated. For each time period, a cost savings function using the respective load factors is formulated. Since, the peak demand charge is usually calculated once on a daily basis, another savings function for the peak power loss reductions is also formulated. Thus, for the example in this method, the savings equations are written as:

$$S_{E1} = K_E \Delta E_1 - K_c C(I_c), \quad (6.13)$$

$$S_{E2} = K_E \Delta E_2 - K_c C(I_c), \quad (6.14)$$

$$S_{E3} = K_E \Delta E_3 - K_c C(I_c), \quad (6.15)$$

$$S_p = K_p \Delta P - K_c C(I_c), \quad (6.16)$$

where:

$S_{E1}$  = energy loss savings from time period 1;

$S_{E2}$  = energy loss savings from time period 2;

$S_{E3}$  = energy loss savings from time period 3;

$S_p$  = peak demand loss savings;

$K_E$  = cost of energy loss reduction, \$/kWh;

$\Delta E_1$  = energy savings in period 1, kWh;

$\Delta E_2$  = energy savings in period 2, kWh;

$\Delta E_3$  = energy savings in period 3, kWh;

$K_p$  = cost of peak power loss reduction, \$/kW;

$\Delta P$  = peak power savings, kW;

$K_c$  = cost of the installed capacitors, \$/kvar; and,

$C(I_c)$  = amount of reactive compensation installed, kvar.

The problem now, is to maximize Equations (6.13–6.16),  $S_{E1}$ ,  $S_{E2}$ ,  $S_{E3}$ , and  $S_P$ , subject to:  $V_{bus} < V_{max}$ , the bus voltage constraint. Considering each of the savings functions as an objective, multi-objective fuzzy optimization is then used. The first step in the procedure is to determine the membership functions for each of these objectives. For this problem of capacitor allocation, each savings objective has a membership function with the following form:

$$\mu_S(I_c) = \begin{cases} 1, & S(I_c) > M_S, \\ \frac{S(I_c) - m_S}{M_S - m_S}, & m_S \leq S(I_c) \leq M_S, \\ 0, & S(I_c) < m_S, \end{cases} \quad (6.17)$$

where:

$m_S = \min S(I_c)$ ; and,

$M_S = \max S(I_c)$ .

There will be four membership functions for each of the savings functions expressed by Equations (6.13–6.16), i.e.  $\mu_{S1}$ ,  $\mu_{S2}$ ,  $\mu_{S3}$ ,  $\mu_P$ . For each of the membership functions,  $m_S = 0$ , and  $M_S$  is found by solving for:

$$\frac{\partial S}{\partial I_c} = 0. \quad (6.18)$$

The membership functions of the savings objectives have the following form as in Figure 6.8.

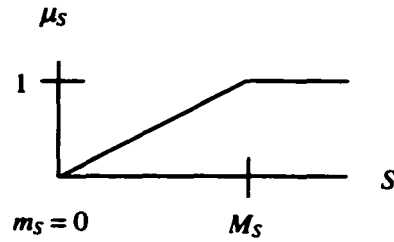

Figure 6.8: Membership Function of Cost Objective

For the capacitor allocation problem, the feeder voltage levels are very important constraints. An effect of capacitor installation is a rise in the feeder voltage level at the point of installation. Thus, overvoltages must be avoided. The voltage rise at the capacitor installation can be approximated by:

$$V_{rise} = I_c X_L, \quad (6.19)$$

where  $X_L$  is the inductive reactance of the feeder circuit, Thus, the voltage of the bus where the capacitor is installed is:

$$V(I_c) = V_{bus} + I_c X_L, \quad (6.20)$$

The membership function for the voltage constraint is given by:

$$\mu_V(I_c) = \begin{cases} 1, & V(I_c) < V_{max}, \\ \frac{(V_{max} + V_{tol}) - V(I_c)}{V_{tol}}, & V_{max} \geq V(I_c) \geq V_{max} + V_{tol}, \\ 0, & V(I_c) > V_{max} + V_{tol}, \end{cases} \quad (6.21)$$

where:

$V_{max} = 1.04$  p.u. is the maximum voltage level; and,

$V_{tol} = 0.03$ p.u. is the additional rise in voltage which can be tolerated for a short period of time.

The values of  $V_{max}$  and  $V_{tol}$  have been determined based on Ontario Hydro Standards 87-3 DP for acceptable distribution system supply voltage ranges [63]. In the standard, an operating voltage range of 0.96-1.04 p.u. is favourable, and voltages of up to 1.07 p.u. are tolerable for short periods. The membership function for the voltage constraint is shown in Figure 6.9.

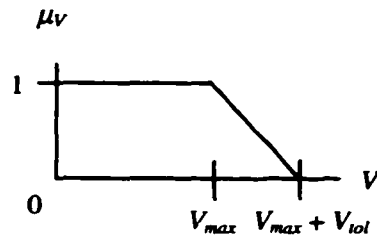

Figure 6.9: Membership Function of Voltage Constraint

Finally, the capacitor sizing problem can now be solved by maximizing  $\mu_C(I_c)$ , the Cartesian product of the membership functions:

$$\mu_C(I_c) = [\mu_{SP}(I_c) \cdot \mu_{S1}(I_c) \cdot \mu_{S2}(I_c) \cdot \mu_{S3}(I_c) \cdot \mu_V(I_c)]^{1/5}, \quad (6.22)$$

Equation (6.22) is maximized without any constraints since the bus voltage constraint is included into the objective function. The solution calculated will not result in any system overvoltages. Once the optimal value of  $I_c$  is determined,

$$S_{tot} = S_P + S_{E1} + S_{E2} + S_{E3} \quad (6.23)$$

is calculated to see if the capacitor provides any substantial savings.

## 6.4 Application of the Planning Method

This capacitor planning method is applied to the same 11kV, 34-bus distribution system used in [41, 46, 47]. A single line diagram of this distribution system is shown in Figure 6.10, and the line and load data are tabulated in Table 6.2.

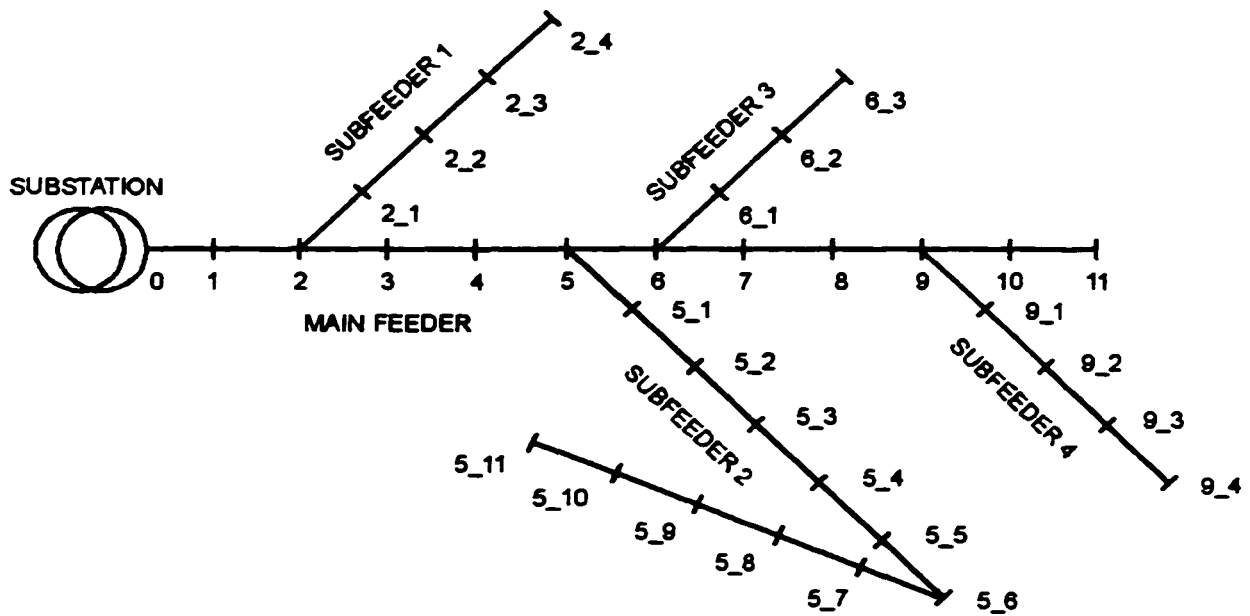

Figure 6.10: One-Line Diagram of 34-Bus Distribution System

Table 6.2: Load and Line Data for 34-Bus Distribution System

Node No.	Load		Line Impedance ( $\Omega/\text{km}$ )		Length (km)	Load Factors		
	P (kW)	Q (kvar)	r	x		$T_1$	$T_2$	$T_3$
1	230	142.5	0.195	0.080	0.60	0.55	0.70	0.65
2	0	0	0.195	0.080	0.55	0	0	0
3	230	142.5	0.299	0.083	0.55	0.55	0.70	0.65
4	230	142.5	0.299	0.083	0.55	0.55	0.70	0.65
5	0	0	0.299	0.083	0.50	0	0	0
6	0	0	0.524	0.090	0.60	0	0	0
7	230	142.5	0.524	0.090	0.40	0.55	0.70	0.65
8	230	142.5	0.524	0.090	0.60	0.55	0.70	0.65
9	0	0	0.524	0.090	0.40	0	0	0
10	230	142.5	0.524	0.090	0.25	0.55	0.70	0.65
11	137	84	0.524	0.090	0.20	0.50	0.60	0.55
2_1	72	45	0.524	0.090	0.30	0.45	0.65	0.60
2_2	72	45	0.524	0.090	0.40	0.45	0.65	0.60
2_3	72	45	0.524	0.090	0.20	0.45	0.65	0.60
2_4	13.5	7.5	0.524	0.090	0.10	0.60	0.70	0.65
5_1	230	142.5	0.299	0.083	0.60	0.55	0.70	0.65
5_2	230	142.5	0.299	0.083	0.55	0.55	0.70	0.65
5_3	230	142.5	0.378	0.086	0.55	0.55	0.70	0.65
5_4	230	142.5	0.378	0.086	0.50	0.55	0.70	0.65
5_5	230	142.5	0.378	0.086	0.50	0.55	0.70	0.65
5_6	230	142.5	0.524	0.090	0.50	0.55	0.70	0.65
5_7	230	142.5	0.524	0.090	0.50	0.55	0.70	0.65
5_8	230	142.5	0.524	0.090	0.60	0.55	0.70	0.65
5_9	230	142.5	0.524	0.090	0.40	0.55	0.70	0.65
5_10	230	142.5	0.524	0.090	0.25	0.55	0.70	0.65
5_11	137.5	85	0.524	0.090	0.20	0.50	0.60	0.55
6_1	75	48	0.524	0.090	0.30	0.55	0.75	0.70
6_2	75	48	0.524	0.090	0.30	0.55	0.75	0.70
6_3	75	48	0.524	0.090	0.30	0.55	0.75	0.70
9_1	57	34.5	0.524	0.090	0.30	0.57	0.63	0.58
9_2	57	34.5	0.524	0.090	0.40	0.57	0.63	0.58
9_3	57	34.5	0.524	0.090	0.30	0.57	0.63	0.58
9_4	57	34.5	0.524	0.090	0.20	0.57	0.63	0.58

### 6.4.1 First Iteration

In the first iteration within the capacitor planning module, the FES determined that node 5\_8 has the highest suitability of 0.65 for capacitor placement. In order to show the inferencing mechanism of the FES, the internal inferencing process for this node is shown. From the load flow, node 5\_8 has a voltage of 0.965 p.u. and after normalizing the losses of each section, the loss index at 5\_8 is 0.967. Thus, from using the loss index and voltage membership functions shown in Figure 6.11 it is determined that node 5\_8 considered as *High-Medium* and *High* loss levels, and *Low-Normal* and *Normal* voltage levels.

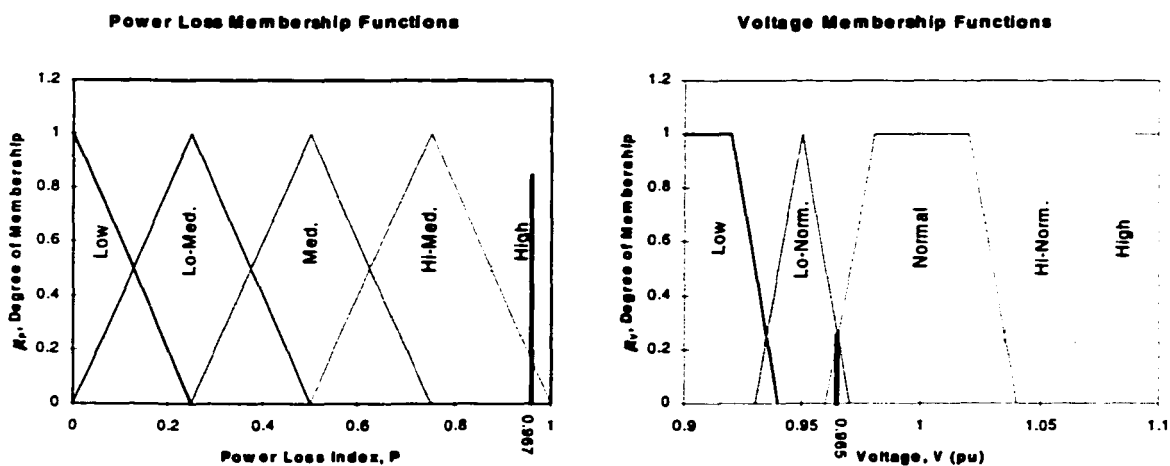

Figure 6.11: Membership Functions for the Power Loss Index and Voltage

Now, using the decision matrix in Table 6.1, it can be seen that the following four rules are fired:

1. If power loss index is *High-Medium* AND voltage is *Low-Normal*, Then capacitor

- placement suitability is *High-Medium*;
2. **If** power loss index is *High-Medium* **AND** voltage is *Normal*, **Then** capacitor placement suitability is *Medium*;
  3. **If** power loss index is *High* **AND** voltage is *Low-Normal*, **Then** capacitor placement suitability is *High-Medium*, and;
  4. **If** power loss index is *High* **AND** voltage is *Normal*, **Then** capacitor placement suitability is *Medium*.

To aggregate the output of the four above rules, the Mamdani max-prod inferencing technique is applied. For the first rule, the membership function of the suitability is found by scaling the consequent membership function to the minimum membership value of the power loss index and the voltage. This is graphically shown in Figure 6.12. Similarly, the same procedure is performed for the second, third, and fourth rules. Figures 6.13-6.15 graphically show the inferencing of rules 2-4 respectively.

Figure 6.12: Graphical Inferencing of Rule 1

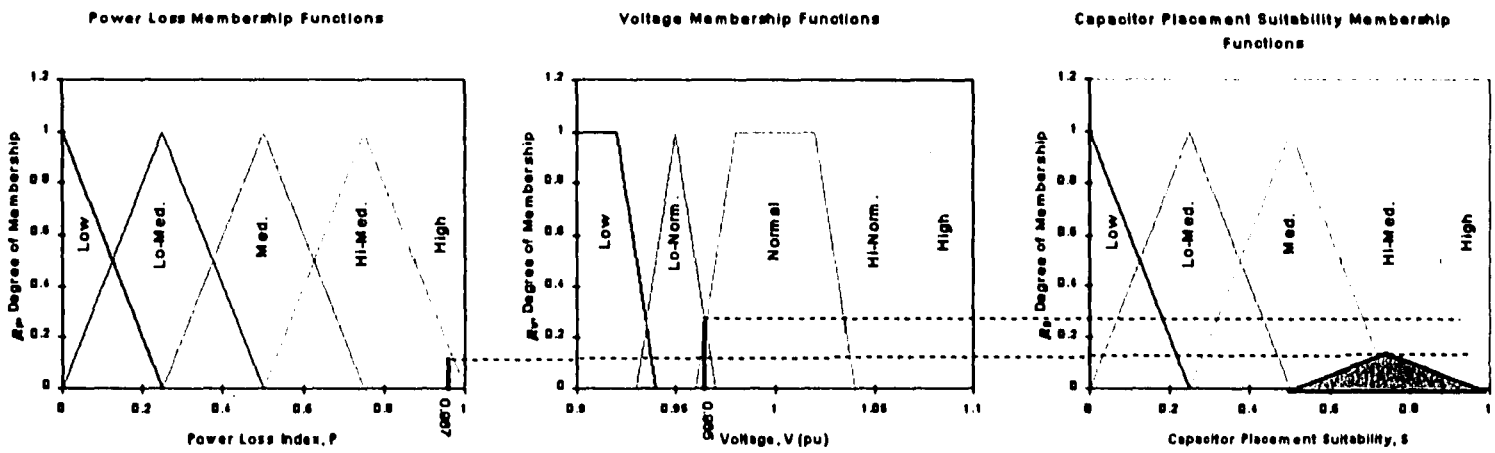

Figure 6.13: Graphical Inferencing of Rule 2

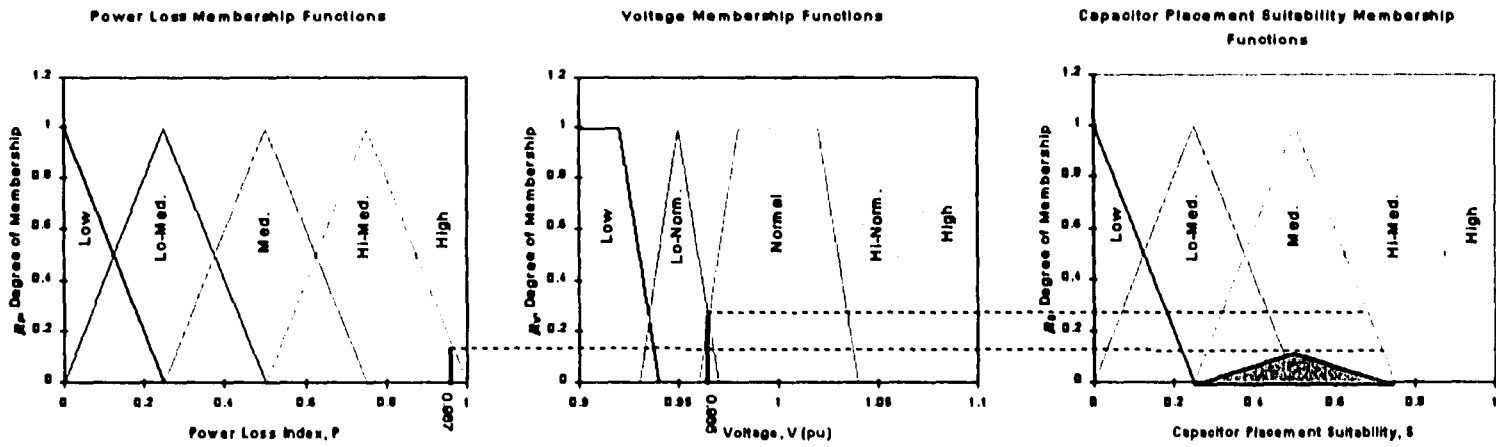

Figure 6.14: Graphical Inferencing of Rule 3

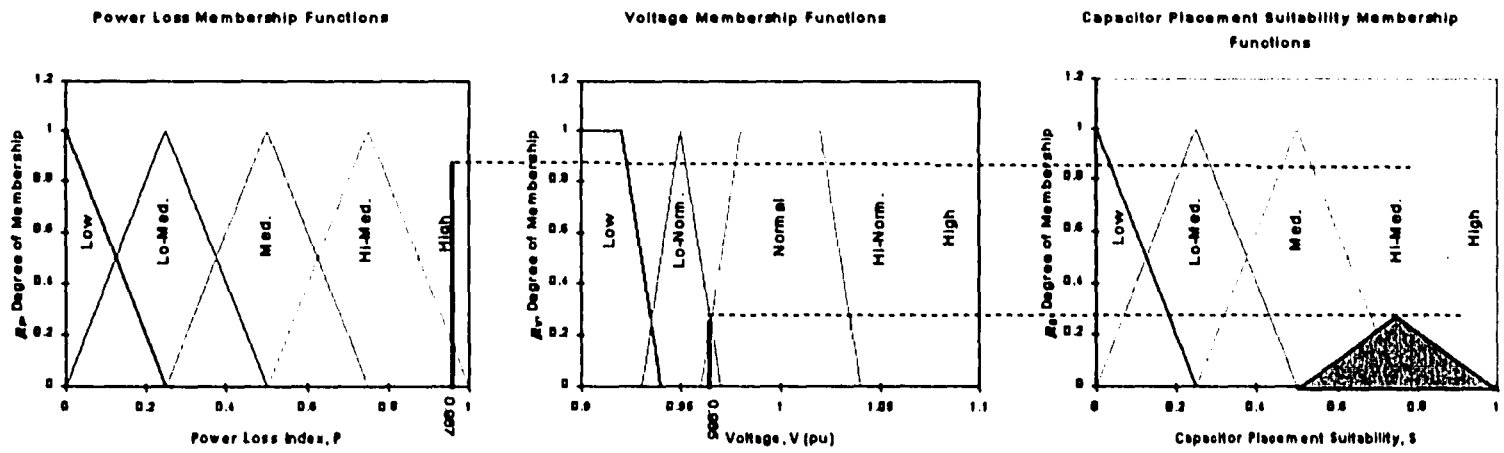
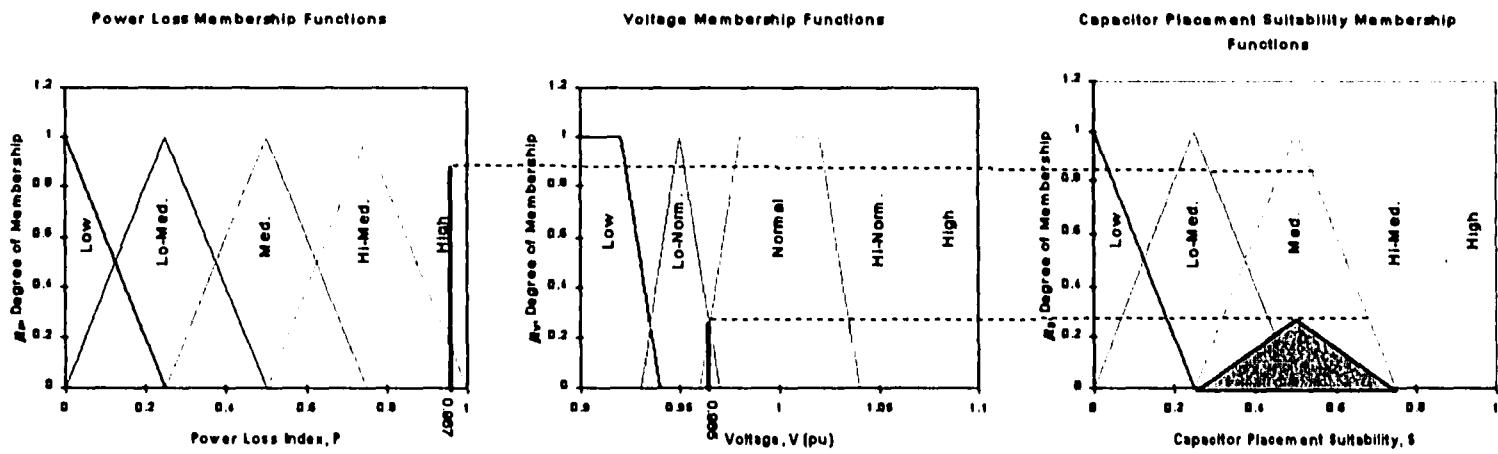

Figure 6.15: Graphical Inferencing of Rule 4



The four consequent membership functions of the capacitor placement suitability are then combined together to form the resulting suitability membership function shown in Figure 6.16. The final membership function in Figure 6.16 is defuzzified using Equation (6.3). The defuzzified value is 0.65.

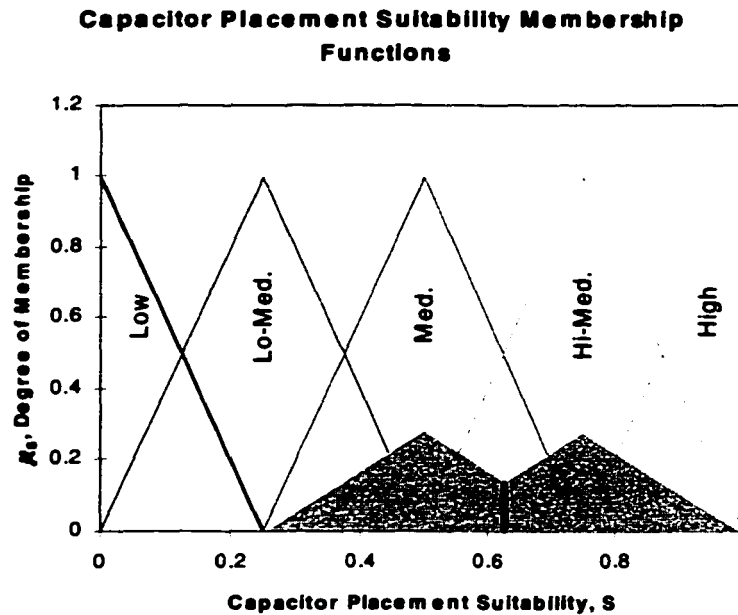

Figure 6.16: Aggregated Membership Function and Defuzzified Value

This procedure is applied to every node of the distribution system. Once the suitability of every node is calculated, the node with highest suitability is the best candidate for capacitor installation.

Now that node 5\_8 has been identified as the most suitable location for capacitor placement, the cost Equations (6.13-6.16) are created and the decision function, Equation (6.22) is optimized. The optimization of Equation (6.22) suggested a capacitor size of 1200 kvar and a actualization of \$30 260 of savings. The

optimization of the decision function is performed as follows: increase the value of  $I_C$  until a maximum is reached. The capacitive current,  $I_C$  is varied at increments equivalent to the amount of injected reactive current by commercially available sizes of capacitors. This is done so that practical solutions would be generated. For the savings calculations, a cost of \$0.07/kWh was used. For the capacitor costs, Figure 6.17 as shown below was used.

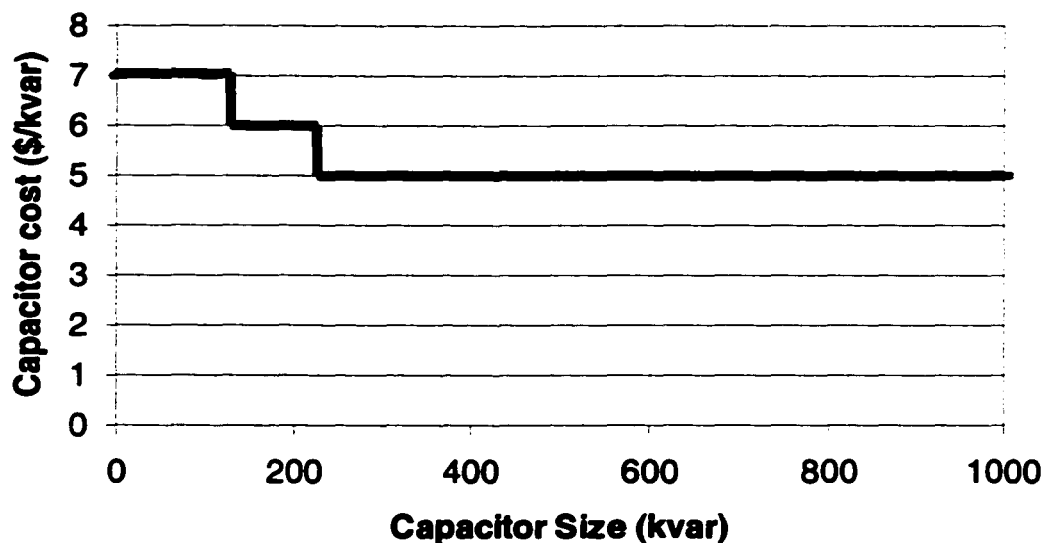

Figure 6.17: Capacitor Cost by Size

Subsequent iterations of the algorithm have yielded nodes, 5\_1 with a capacitor of 750 kvar and savings of \$22 568, and node, 6 with a 600 kvar capacitor and savings of \$7 400. The fourth iteration of this algorithm did not produce any additional economic savings. Thus, the total savings with all three capacitors installed results in net annual savings of \$60 236.

In [41, 47], crisp methods of capacitor allocation have been applied to the same

distribution system as considered in this example . Their respective savings calculated are \$57 748, and \$63 234. These savings are close to that achieved by the method presented in this paper. However, to better appreciate the merits of the multi-objective fuzzy approach, it must be realized that the methods in [41, 47] assume that all input data are exact. This is not an assumption made by this multi-objective fuzzy method. To further illustrate this point, consider Table 6.3 which summarizes the results using the multi-objective fuzzy optimization technique. In Table 6.3, the maximum savings of each time period,  $M_{S1}$ ,  $M_{S2}$ ,  $M_{S3}$  resulting from capacitor installation at the chosen node are tabulated. Note, that despite the differences in the load factor used to calculate the savings, the difference between the largest and the smallest savings is only about 10%. Therefore, if load data is only measured for a portion of the day, this fuzzy optimization method can still produce reasonable solutions. In addition, the largest and smallest values of  $M_S$  of the different time periods can also be used as bounds for the amount of savings that can be achieved. This is especially useful when there is uncertainty in the load data. The distribution engineer can have some confidence as to a worse case for the amount of savings that can be achieved and whether or not it is worth the initial capital expenditure for the installation of the capacitors. Thus, no matter how well or poorly the load information may reflect the actual behaviour of the distribution system; this multi-objective fuzzy optimization capacitor allocation method determines the most appropriate placement and sizes of capacitors. This solution best reconciles the varying load patterns and the imposed voltage constraints of the system.

Furthermore, a final load flow calculation with all three capacitors installed has confirmed that all bus voltages of the system are in the acceptable operating ranges.

Table 6.3: Results

Node	Savings For Each Time Period			Final Savings	Capacitor Size kvar
	$M_{S1}$ , (\$)	$M_{S2}$ , (\$)	$M_{S3}$ , (\$)		
5_8	29 672	33 458	31 569	30 268	1200
5_1	19 854	23 958	22 985	22 568	750
6	6 343	9 500	7 575	7 400	600
Total				\$60 236	25050kvar

## 6.5 Switched Capacitors

Several of the capacitor placement techniques reviewed in Chapter 3 also include the allocation of switched capacitors in distribution systems [19, 20, 25, 34, 35]. In these methods, a time interval for the capacitors to be switched on is either determined by the discretion of the distribution engineer or by calculating an optimal time period. For the techniques found in [19] and [34], the authors suggest that the distribution engineer examine the load duration curves for the system and determine the time period that is considered on-peak for capacitor switching. However, no specific method is given to determine what load level is considered as on-peak load. In [20, 25, 35], the time period for capacitor switching is determined by dividing the load duration curve into time periods and performing the capacitor allocation

optimization method for each time period. Once capacitor allocation has been performed for each time period, the nodes which require capacitors all the time are set to contain fixed capacitors and the nodes which require capacitors for only some of the time are to have switched capacitors. For these methods which require the distribution engineer to specify the time periods for the capacitor switching, the quality of the solution is dependent on the distribution engineer's experience in determining the behaviour of the distribution system.

For the methods found in [20, 25, 35], a conforming load duration curve is used in the optimization procedure to determine which capacitors are specified to have a switching ability and which capacitors are to remain as fixed. Specific time periods for the operation of the switched capacitors are also determined for the maximum loss reduction of the system. These methods are not realistic as the load consumption will never follow a "conforming" load profile all the time. In addition, since loads are non-deterministic, it is also not practical to pre-specify a capacitor dispatch scheme as these methods have done.

In the proposed method, a FES identifies nodes that are likely to require a switched capacitor. The rules of this FES and the rationale of the method are described in detail in the next subsection. Control of the switched capacitors is left to the operation module of the proposed method which is discussed in Chapter 7.

### 6.5.1 Determining Switched Capacitors

Section 6.2 has described a fuzzy method to determine suitable locations for capacitor installation and section 6.3 has detailed a method for sizing fixed capacitors for the suitable locations found. Fixed capacitors are suitable for steady loads which do not have a large variance. For loads that swing widely and have a shorter lasting peak, switched capacitors are more appropriate. One way of determining whether a load is considered as steady or has a short lasting peak is by examining its load and loss factor.

By definition, load factor is [66]:

$$F_{LD} = \frac{\Delta \text{ average load}}{\text{peak load}} \quad (6.24)$$

Thus, a load factor approaching the value 1 indicates that the average load is very close to the peak and the load is steady. However, a low load factor indicates the opposite, of a load that has more variation with time. Similarly, the loss factor is defined as [66]:

$$F_{LS} = \frac{\Delta \text{ average power loss}}{\text{peak power loss}} \quad (6.25)$$

The loss factor only applies to the  $I^2R$  losses of the system. Therefore, a loss factor approaching to the value 1 indicates that the load currents are quite steady; whereas a smaller loss factor indicates more varying load currents. An investigation by

Westinghouse Electric Corporation [67] has found 2 limiting relationships between the load and loss factors:

- If the load is steady, the value of the loss factor approaches the value of the load factor,

$$F_{LS} \rightarrow F_{LD} . \quad (6.27)$$

- If the load has a very short lasting peak, the value of the loss factor approaches to the square of the load factor,

$$F_{LS} \rightarrow F_{LD}^2 . \quad (6.28)$$

Using these relationships in Equations (6.27) and (6.28), Buller *et al* [68] developed an approximate formula to relate the loss factor to the load factor. This formula is given as:

$$F_{LS} = 0.3F_{LD} + 0.7F_{LD}^2 \quad (6.29)$$

Using Equation (6.29), several rules can be established to determine whether a suitable capacitor location requires a fixed or switched capacitor. The rules are:

- If the load factor is approaching a value of 1 or is considered *high*, the loss factor is also *high* indicating that the load is steady, **Then** only a fixed capacitor is required.
- If the load factor is *low*, the loss factor is even *lower* indicating that the load varies widely with a shorter peak, and a much higher losses occur during the peak, **Then** a switched capacitor is desired.

Once again, note that the above rules use linguistic terms to describe the load and loss factors. Further investigation of the load factor can also aid in determining the sizes of the switched capacitor required for the nodes suited for switched capacitors. In [66], Gonen determined a generalized equation relating the optimum energy loss reduction with the load factor. This equation is given by:

$$\Delta EL_{opt} = \frac{3\alpha C_T}{1-\lambda} \left[ F_{LD} - C_i + \frac{C_T^2}{4F_{LD}} \right] T, \quad (6.30)$$

where:

$$\alpha = \frac{1}{1 + \lambda + \lambda^2};$$

$$\lambda = \frac{\text{reactive current at end of feeder segment}}{\text{reactive current at the beginning of feeder segment}}; \text{and,}$$

$C_T$  = total capacitor compensation.

If the quadratic Equation (6.30) is plotted against the per-unit total reactive compensation level,  $C_T$  for various load factor values, one will notice that the optimum level of reactive compensation is best when the value of the per-unit total reactive compensation is close to the loss factor. Thus, using this correlation, and given the Equations (6.27–6.30), a formal set of three fuzzy rules can be established to determine if a node is suitable for a switched capacitor and also the amount of compensation level that should be switched on during peak periods. Again, these rules are in the If ... Then form:

- **If** load factor,  $F_{LD}$  is *high*, **Then** use only a fixed capacitor of the size, 100 % of the compensation level found.

- **If** load factor,  $F_{LD}$  is *medium*, **Then** use a fixed capacitor of the size,  $0.3F_{LD} + 0.7F_{LD}^2 \times 100\%$  of the compensation level found and a switched capacitor for the remainder of the compensation level.
- **If** load factor  $F_{LD}$  is *low*, **Then** use a fixed capacitor of the size  $F_{LD}^2 \times 100\%$  of the compensation level found and a switched capacitor for the remainder of the compensation level.

For this type of fuzzy rule base inferencing, the fuzzy variable is the load factor. The membership functions for the load factor are shown in Figure 6.18. Since these rules involve using mathematical relationships expressed by Equations (6.27-6.29) and linguistic descriptors to describe the load factors, the Mamdani [65] inferencing method previously used to determine the capacitor placement suitability index cannot be used. Instead a method based on Takagi and Sugeno [69] is used. The Takagi and Sugeno method of fuzzy implication differs from the Mamdani approach in that the consequent in the rule is a function and not a linguistic fuzzy term. An example of this is shown by the following rule:

**If** the premise  $x_i$  belongs in the fuzzy set  $A_i$ ,

**Then** the corresponding action is  $y_i = f(x_i)$ ,

where  $i$  denotes the  $i^{\text{th}}$  variable of the premise. The three rules as outlined for determining switched capacitor sizes are formed in such a structure. If multiple inferences occur, the final output is determined by:

$$y_f = \frac{\sum \mu(x_i) y_i}{\sum \mu(x_i)}, \quad (6.31)$$

where  $\mu(x_i)$  is the degree of membership of the element  $x_i$ . The next subsection details an illustrative example of this inferencing.

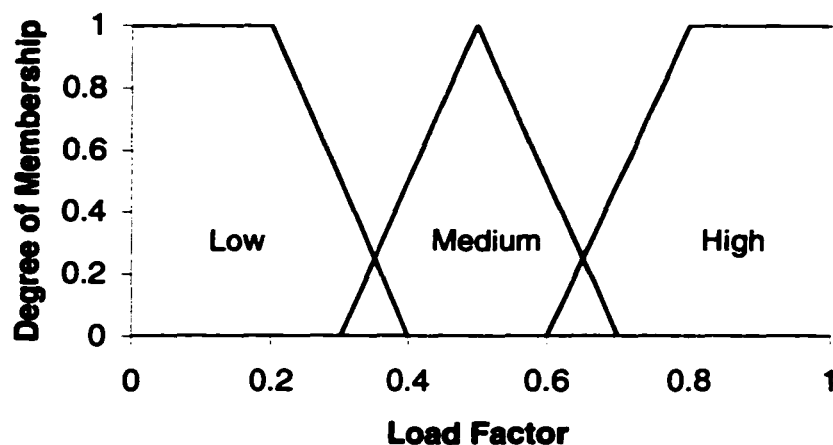

Figure 6.18: Membership Functions for Load Factor

### 6.5.2 Application of the Switched Capacitor Planning Method

Using the same system as in section 6.4, it was previously determined that node 5\_8 is the most suitable location for capacitor placement. The annual load factor for this node is 0.65. By inspecting Figure 6.19, the membership functions of the load factor, a value of 0.65 is considered as both *medium* and *high*. Thus, this node qualifies to have a switched capacitor.

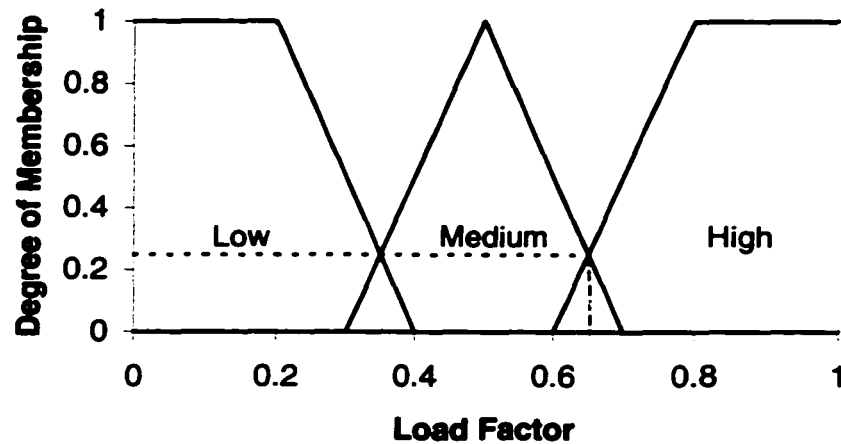

Figure 6.19: Membership Functions of Load Factor

In order to determine the total compensation of this node, the size of the capacitor for this node is determined by maximizing for the best power savings based on the peak load. The following savings function is used:

$$\Delta S = K_p \Delta P - K_c C - F \quad (6.32)$$

where:

$K_p$  is the cost of power in \$/kW;

$\Delta P$  is the reduction in power loss due to capacitor placement;

$K_c$  is the cost of the capacitor in \$/kvar;

$C$  is the capacitor size in kvar; and,

$F$  is the additional fixed cost of installing a switched capacitor.

The same costs as in section 6.4 are used, but an additional fixed cost of \$500 is included for the installation of a switched capacitor. The additional fixed cost of \$500 for the installation of a switched capacitor is relatively inexpensive as compared

to the costs of ten years ago [70]. By optimizing Equation (6.32) a capacitor size of 1500kvar is determined. To determine how much of the 1500kvar compensation to set as fixed and switched, the load factor of the node is looked at again. As determined earlier, a load factor of 0.65 is considered as both *medium* and *high*. In the case where the load factor is considered as *medium*, the amount of compensation to be fixed is given by  $0.3F_{LD} + 0.7F_{LD}^2$  which yields 0.49 with a membership value of 0.25. For the case where the load factor is consider *high*, the fixed compensation is 1.0 with also a membership value of 0.25. To aggregate the implications, Equation (6.32) is used. This yields a final solution of  $\frac{0.49 \times 0.25 + 1 \times 0.25}{0.25 + 0.25} = 0.645$ . Therefore, the fixed capacitor size should be  $0.645 \times 1500 = 968$ kvar. In which case, the 968kvar is rounded up to 1000kvar leaving 500kvar as the switched component of the compensation.

Subsequent iterations of this method have determined a fixed 750kvar and switched 250kvar capacitors at node 5\_1 and fixed 600kvar and switched 150kvar capacitors at node 6.

This method of determining the amount of compensation to consider as fixed or switched does not assume that all loads in the distribution system follow a predictable load duration curve. By using the relationships between the load and the loss factors, the best compromise for compensating loads during off-peak and on-peak is found.

## **6.6 Summary**

This chapter has detailed two methods for proper capacitor allocation for loss reduction. The first method plans for only fixed capacitors in the distribution system. The use of multi-objective fuzzy optimization to determine the sizes of fixed capacitors takes into account of the varying nature of the distribution system nodes and guarantees the prevention of overvoltage violations. The method intuitively assigns values to the objectives through the use of fuzzy membership functions. The second capacitor allocation method determines sizes for both fixed and switched capacitors. For this method, the sizes of the fixed and switched capacitors are not determined by assuming a fixed interval of time for the dispatch of the capacitors. The suitability of installing a switched capacitor is dependent on the load factor and the loss factor. These factors characterize the load as being steady and only requiring a fixed capacitor or as widely varying and requiring both fixed and switched capacitors.

For both capacitor allocation methods, any uncertainty in the system data is inherently accounted for and the solutions calculated by the fuzzy approaches reflect the most favourable compromise solution.

The next chapter describes a scheme for effective dispatch of switched capacitors. To continue with the theme of using FST in this thesis, a capacitor control method using a FES is presented.

## **7 Control of Capacitors**

### **7.1 Introduction**

As reviewed in Chapter 3 a considerable amount of work has been done on the planning aspects of capacitor allocation in distribution systems. However, work on real-time control and dispatch of capacitors in distribution systems has been limited. The next subsections provide a brief literature survey of capacitor control schemes and describe the capacitor control scheme used in the proposed distribution system enhancement program.

## 7.2 A Review Capacitor Dispatch Schemes

Some of the capacitor allocation techniques described Chapter 3 also include methods for capacitor dispatch [32, 34, 48, 49, 50]. In all these methods, the loads of the system are assumed to have a conforming load curve, and capacitor switching schedules are established based on these curves. Thus, every switched capacitor in the system has set times to be turned on and off each day. Again, as mentioned in the previous chapter, distribution loads are not deterministic and the varying load cannot be predicted. By using such capacitor dispatch schemes, it is possible that overvoltages or even an increase in losses may occur due to overcompensation.

Fortunately, almost all distribution systems in North America are equipped with Distribution Automation (DA) and SCADA systems for some continuous monitoring of feeder section loads. Therefore, capacitors can be switched on and off via remotely controlled switches [71]. Hsu *et al.* [72] and Salama *et al.* [73] developed techniques using dynamic programming to help distribution system operators determine daily optimal capacitor dispatch.

Although the methods of [72, 73] take advantage of the system information from the SCADA system, there is no facility for any interaction with the system operators. Input from the operators is not considered, and the information conveyed to them is just a series of capacitor switching commands. As already noted in Section 3.5, one of the main dissatisfactions of users of power system applications is the lack of, or poor user interaction. And, as described in Chapter 4, one of the main

advantages of using fuzzy systems is its ability to convey information to users in a linguistic manner. Hence, fuzzy systems have an inherently user-friendly interface. The next section describes an interactive capacitor control system that is part of the proposed distribution system enhancement package.

### **7.3 Capacitor Control by Fuzzy Inferencing**

The capacitor control module of the proposed system is based on using the same fuzzy rules as defined for determining the suitable candidate nodes for capacitor placement. In a similar fashion, the rules set for capacitor control determine the most suitable switched capacitors to operate for the best distribution system performance. Figure 7.1 illustrates the flow of data in the fuzzy capacitor control scheme. SCADA information which includes voltage and load information, and operator input are entered into the fuzzy capacitor controller. The fuzzy capacitor controller includes a facility to calculate the losses of each section of the distribution system and compute a set of loss reduction indices. These loss reduction indices are calculated the same way as outlined in Section 6.2. The loss reduction index and voltage of each node with a switched capacitor, and an operator assessment of the status of the distribution system are inputs to a FES which determines the most suitable capacitors to switch on or off. The rules of the FES are described in the next section.

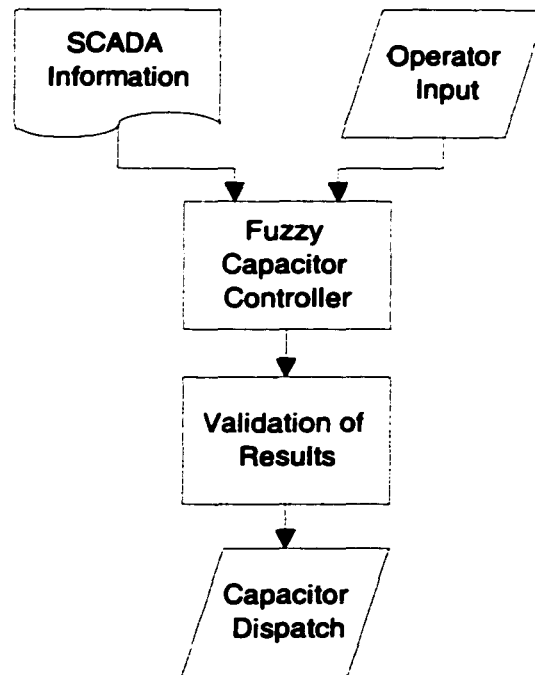

Figure 7.1: Fuzzy Capacitor Control Module

## 7.4 FES For Capacitor Control

The fuzzy rules for capacitor controls are based on the rules established in Section 6.2 for capacitor control. However, rather than identifying suitable nodes for capacitor placement, this FES identifies suitable switched capacitors to turn on or off. For example one rule for switching on a capacitor is:

**If** the section losses are *high* and the voltage is *low*,

**Then** it is suitable for the capacitor to be switched on.

The fuzzy rules to determine the suitability of a capacitor to be switched on are contained in the decision matrix in Table 7.1. The membership functions used for the

power loss index and the voltage are the same as the ones established for capacitor placement and can be found in Figures 6.2 and 6.3 of Chapter 6.

Table 7.1: Decision Matrix for Capacitor Switching

AND		Voltage				
		Low	Low – Normal	Normal	High – Normal	High
Power Loss Index	Low	<b>Low – Medium</b>	<b>Low – Medium</b>	<b>Low</b>	<b>Low</b>	<b>Low</b>
	Low – Medium	<b>Medium</b>	<b>Low – Medium</b>	<b>Low – Medium</b>	<b>Low</b>	<b>Low</b>
	Medium	<b>High – Medium</b>	<b>Medium</b>	<b>Low – Medium</b>	<b>Low</b>	<b>Low</b>
	High – Medium	<b>High – Medium</b>	<b>High – Medium</b>	<b>Medium</b>	<b>Low – Medium</b>	<b>Low</b>
	High	<b>High</b>	<b>High – Medium</b>	<b>Medium</b>	<b>Low – Medium</b>	<b>Low – Medium</b>

To incorporate of the system operator's input, the loss indices and voltages can be further hedged before they are input into the FES for custom control of the capacitors. Hedging is a method of modifying fuzzy terms to further enhance the ability to describe qualitative concepts. An example of this is:

The load is *very* high.

Here, the modifier *very* further emphasizes that the load is more than just high. For this fuzzy capacitor control scheme, the system operator is allowed to hedge the loss

index and the voltage by using the modifiers, *very* and *somewhat*. To illustrate the use of these hedges, consider the following: If the system operator feels that a particular section has *very* high losses in comparison to other sections, or that the voltage may only be *somewhat* low, he may choose to hedge the loss index and voltage inputs before they are entered into the FES for capacitor control.

In FST, hedges are applied to fuzzy terms by changing the shape of the membership functions. For the modifier *very* the hedge is applied to the membership function as such:

$$\mu'(x) = 2 \cdot \mu(x), \quad (7.1)$$

where  $\mu'(x)$  is the hedged membership function. Similarly, the modifier *somewhat* is applied in this manner:

$$\mu'(x) = \frac{1}{3} \cdot \mu(x), \quad (7.2)$$

The value of the hedge coefficients are subject to the system operator's discretion. In Equations (7.1) and (7.2), the coefficients are the default values used in the FuzzyClips [64] program that is used to perform the fuzzy inferencing for the capacitor control.

The frequency of updated inputs to the capacitor controller is subject to the operational policies of the utility. In the next section where an example is given, data to the controller is updated on an hourly basis. To allow sufficient time for the capacitor to discharge, subsequent capacitor switching should not occur within 3

minutes according to the Ontario Hydro Distribution Engineering Technical Guide [74].

## **7.5 An Example of Using the Fuzzy Capacitor Controller**

To demonstrate the ability of the fuzzy capacitor controller, it is tested on the 34 bus distribution system as detailed in Section 6.4. The loads in this 34 bus system are mostly of residential and commercial types and less of the industrial type. Table 7.2 shows the types of load at each node of the 34 bus system.

In order to perform the simulations, daily load curves were established for each of the three load types. The method used to generate the load curves was based on the studies done by Wagner [75] in collaboration with Ontario Hydro. These studies indicated that loads follow a similar daily pattern that can be divided into three seasons:

- **Spring/Fall:** March, April, May, September, October, November;
- **Summer:** June, July, August;
- **Winter:** December, January, February.

In addition, within each season, the weekend load pattern is different from that of a weekday load pattern. Therefore the annual system load characteristics can be characterized by 18 load profiles, (3 load types  $\times$  3 seasons  $\times$  2 types of day profiles). Wagner's investigations with Ontario Hydro also found that industrial daily load profiles did not change significantly with the seasons or whether it was a weekend or

weekday. It was also found that spring/fall load profiles were similar to those of the winter season, but only about 75% of the winter demand.

Based on these findings, five load profiles were created to test the fuzzy capacitor control system. It was assumed that the industrial load profile did not change throughout the year and that the residential and commercial loads had the same daily load profiles. The load profiles are shown in Figures 7.2-7.6.

Table 7.2: Load Types of 34 Bus System

Node No.	Type of Load
1	Industrial
2	Industrial
3	Industrial
4	Industrial
5	Industrial
6	Industrial
7	Industrial
8	Industrial
9	Industrial
10	Industrial
11	Industrial
2_1	Residential
2_2	Residential
2_3	Residential
2_4	Residential
5_1	Residential
5_2	Residential
5_3	Residential
5_4	Industrial
5_5	Commercial
5_6	Commercial
5_7	Commercial
5_8	Industrial
5_9	Industrial
5_10	Residential
5_11	Residential
6_1	Residential
6_2	Residential
6_3	Residential
9_1	Commercial
9_2	Commercial
9_3	Commercial
9_4	Commercial

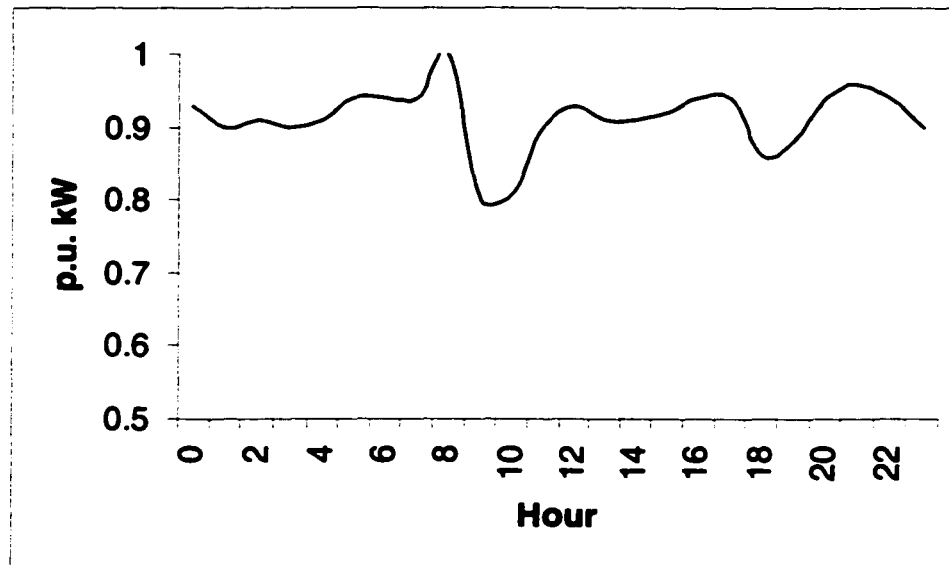

Figure 7.2: Daily Load Profile for Industrial Loads

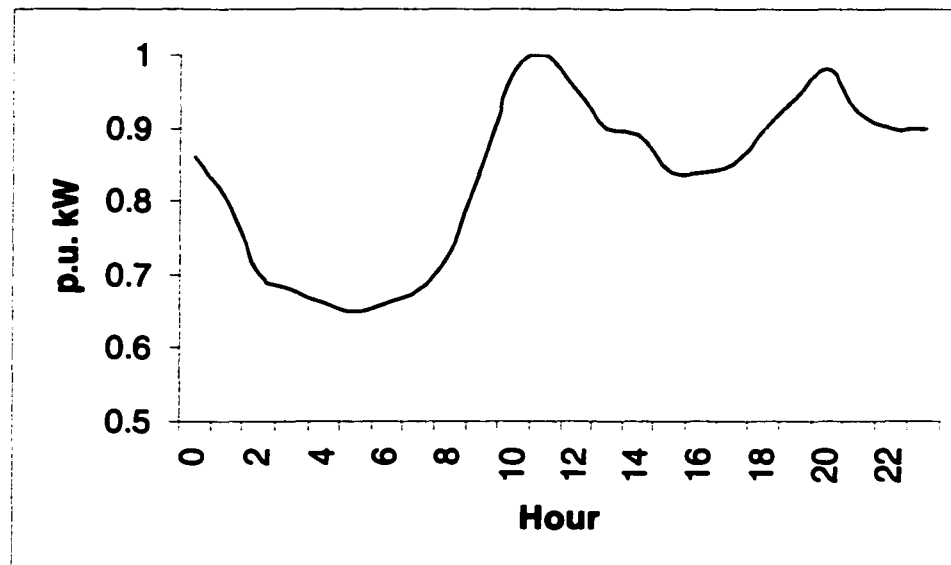

Figure 7.3: Daily Load Profile for Residential Loads on a Winter Weekday

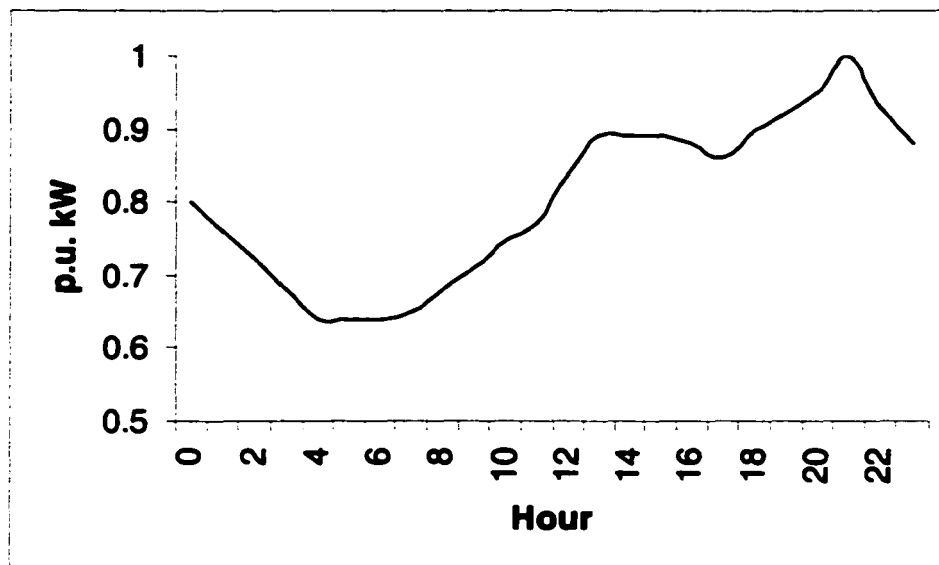

Figure 7.4: Daily Load Profile for Residential Loads on a Winter Weekend

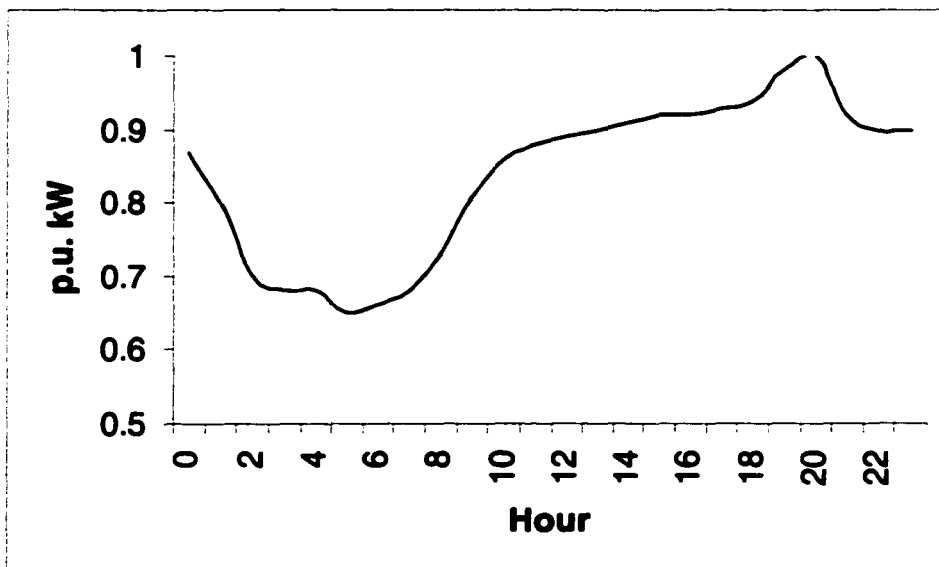

Figure 7.5: Daily Load Profile for Residential Loads on a Summer Weekday

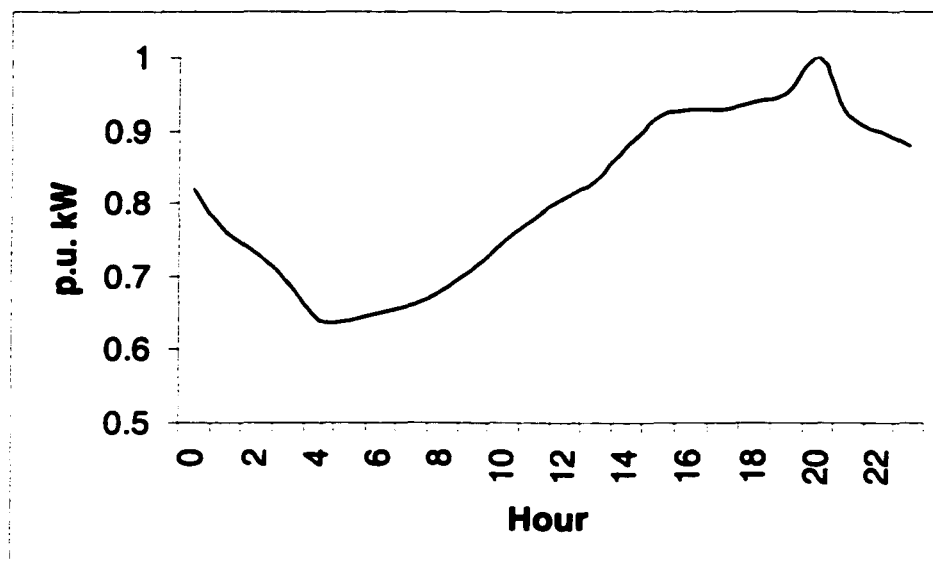

Figure 7.6: Daily Load Profile for Residential Loads on a Summer Weekend

### 7.5.1 Simulation Results

The performance of the fuzzy capacitor controller was examined for the three seasons as described previously. For the test cases, no operator hedging was used. Tables 7.3 and 7.4 indicate the daily capacitor dispatch schedule for a typical day for each of the seasons. In all cases, each capacitor is only required to be switched on/off no more than twice daily. Some utilities may have an operational procedure of minimal capacitor switchings. In such cases, the operator can hedge the inputs to the fuzzy capacitor control so that capacitors are only switched on during situations of *very high losses* or *very low voltages*.

Table 7.3: Weekday Capacitor Dispatch

		Hour																							
Season	Capacitor	0	1	2	3	4	5	6	7	8	9	10	11	12	13	14	15	16	17	18	19	20	21	22	23
Spring/Fall	5_1																								
	5_8																								
	6																								
Summer	5_1																								
	5_8																								
	6																								
Winter	5_1																								
	5_8																								
	6																								

Capacitor Switched On  
 Capacitor Not Switched

Table 7.4: Weekend Capacitor Dispatch

		Hour																							
Season	Capacitor	0	1	2	3	4	5	6	7	8	9	10	11	12	13	14	15	16	17	18	19	20	21	22	23
Spring/Fall	5_1																								
	5_8																								
	6																								
Summer	5_1																								
	5_8																								
	6																								
Winter	5_1																								
	5_8																								
	6																								

Capacitor Switched On  
 Capacitor Not Switched

To further demonstrate the performance of the fuzzy capacitor controller, Figures 7.7-7.10 indicate the savings contribution from the switching of the capacitors for typical winter and summer days. As expected, with the capacitor switching, loss savings are greater during peak hours.

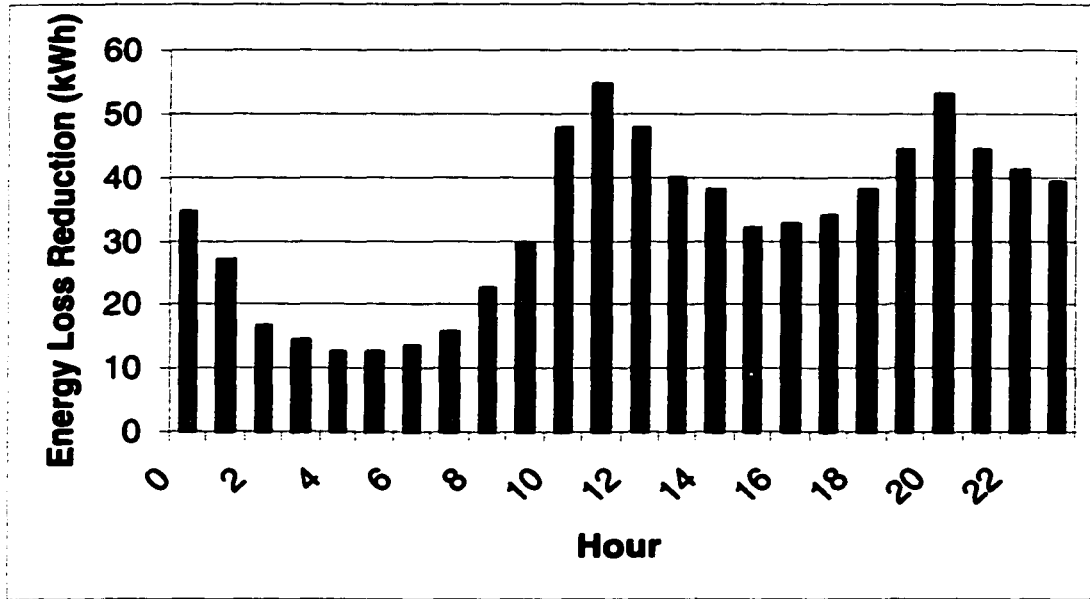

Figure 7.7: Energy Loss Reduction for a Typical Winter Weekday

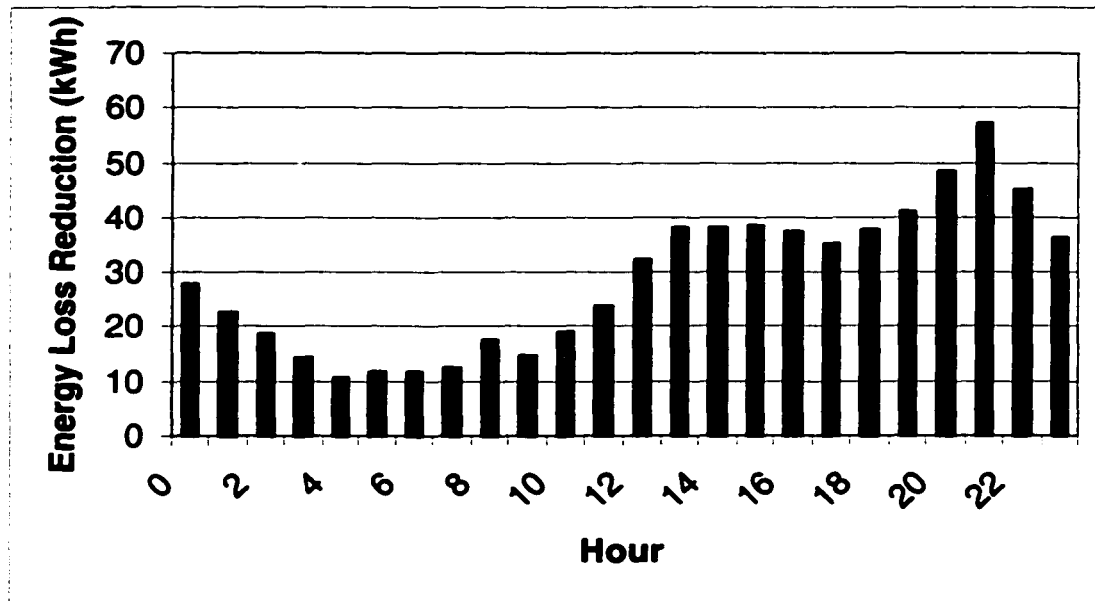

Figure 7.8: Energy Loss Reduction for a Typical Winter Weekend Day

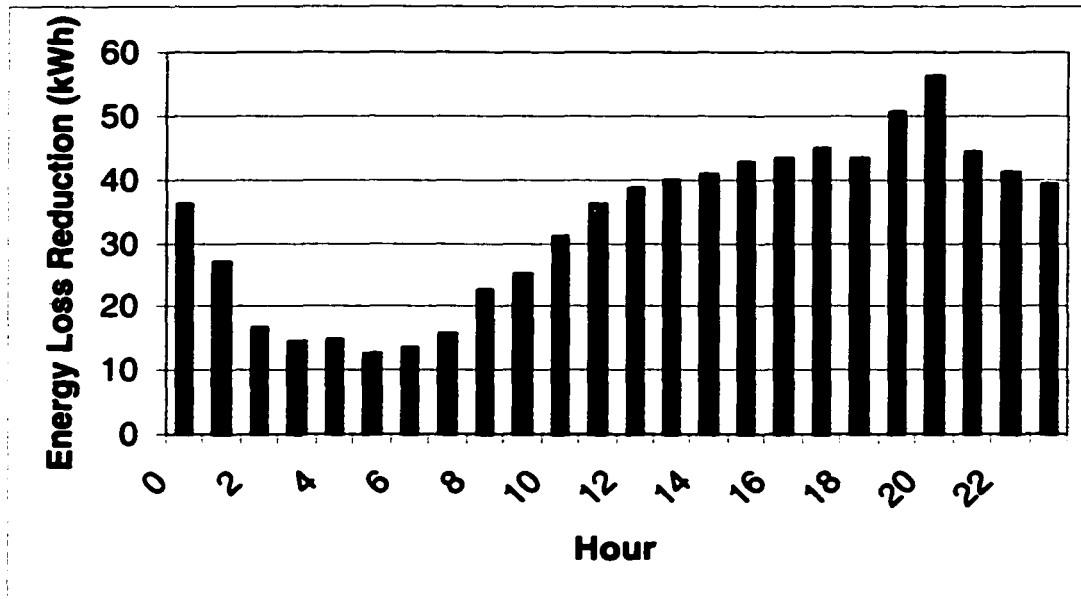

Figure 7.9: Energy Loss Reduction for a Typical Summer Weekday

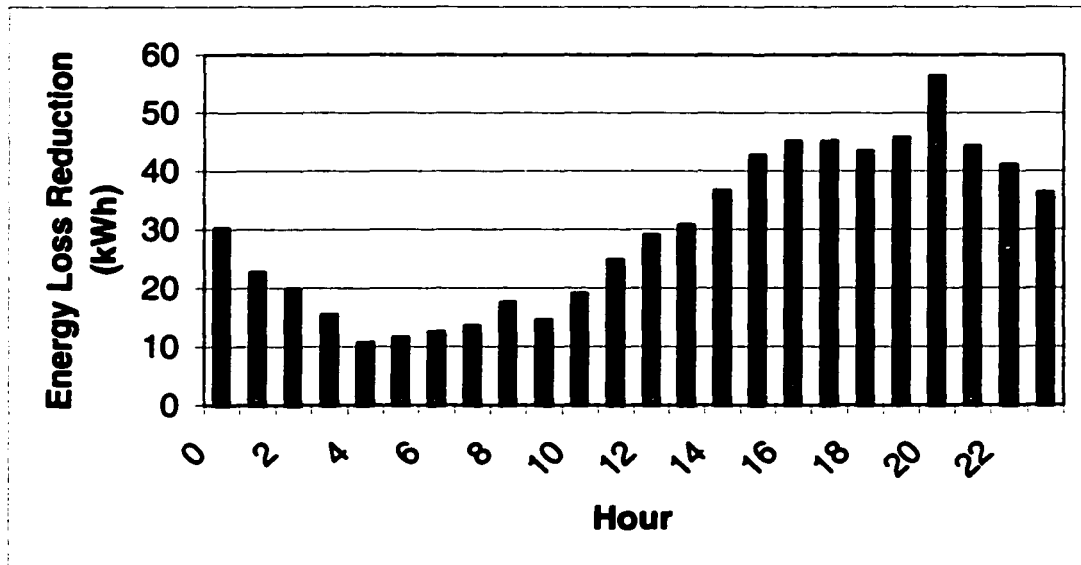

Figure 7.10: Energy Loss Reduction for a Typical Summer Weekend Day

## **7.6 Summary**

This chapter has shown an effective and intuitive means for the dispatching of switched capacitors for loss reduction. Unlike many commercially available capacitor controllers which switch on and off capacitors on a time basis or at a particular voltage level, the fuzzy capacitor controller uses approximate reasoning to determine which capacitors to switch on and off. The rationale of the capacitor dispatches is justified to system operators by current voltage and loss states of the distribution system. Furthermore, operator input can be used to hedge the inputs into the FES for better control of switched capacitors. A demonstration of the operation of the fuzzy capacitor controller has confirmed such advantages.

One effect of proper capacitor switching is the flattening of a feeder's voltage profile. This improvement in feeder voltage profile can be advantageous to utilities choosing to adopt CVR into their loss reduction strategies. The next chapter discusses in detail effective CVR for distribution system loss reduction.

## **8 Conservative Voltage Reduction**

### **8.1 Introduction**

As briefly introduced in Chapter 2, Conservative Voltage Reduction (CVR) is a cost cutting measure that electric utilities perform by lowering the substation voltages a few percent to reduce the peak demand (peak shaving) and/or the energy consumption. Several large American utilities including Southern California Edison [10], Bonneville Power Administration [76], and Florida Power and Light [77] have experienced varying degrees of success in loss reduction by using CVR. The Detroit Edison Company [78] also reported reductions in real and reactive demand by lowering distribution primary feeder voltages. However, their study concluded that CVR was not a practical and cost effective means of loss reduction. As with any loss reduction strategy, the success of its implementation is highly system dependent. In particular to CVR, loss and consumption reduction is determined predominantly by

the voltage sensitivity of the loads. Thus, this chapter focuses on load modeling, and load sensitivity to voltage. In addition, effective CVR operation with a complementing capacitor allocation program is explained.

## **8.2 Load Flow Analysis for Distribution Systems**

Load flow analysis is an important and fundamental tool for the study of power systems. Specific to distribution systems, load flows are required for distribution system design, planning, and operation. In many cases, the loads in distribution systems are sensitive to voltage variations. Nevertheless, Gauss-Seidel and Newton-Raphson load flow methods using a constant PQ model, are often used in many of these distribution system studies. These methods using a constant complex power model are more applicable to transmission systems where the voltage is usually regulated, and are not suited for distribution system studies [79]. Hence, a formulation of a ladder network-based load flow method appropriate for distribution system analysis is described in the next section. This load flow program has been used to perform the analysis in this thesis.

### **8.2.1 Ladder Network Theory**

The ladder network-based load flow equations involve the circuit equations of Kirchoff's laws. Figure 8.1 is a ladder network representation of a single distribution

feeder.  $V_n$ ,  $S_n$ ,  $Z_n$  are the respective voltage, load, and section impedance of node  $n$  of the feeder.

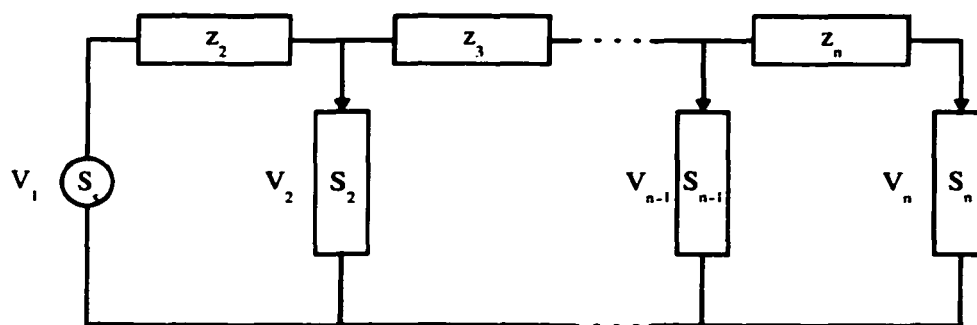

Figure 8.1: Ladder Network Representation of a Single Feeder

For the first iteration of the load flow, it is assumed that all the node voltages have a voltage of  $V_1$  at the source node. The currents drawn by each of the loads are then calculated by:

$$I_n = \left( \frac{S_n}{V_n} \right)^* \quad (8.1)$$

The currents flowing through each section of the feeder are calculated by summing the load currents downstream of the section. The node voltages can then be calculated by:

$$V_n = V_{n+1} + I_{n+1} Z_{n+1} \quad (8.2)$$

The newly calculated voltages are used to recalculate the load currents using Equation (8.1). This process is repeated until the differences between the node voltages of subsequent iterations are less than a desired tolerance.

The load flow method just described above calculates the system voltages and currents for only one feeder. To expand this idea for a radial distribution system of many laterals and sublaterals, each sublateral of the system is treated as a single ladder

network and solved for. Then, each sublateral is inserted into the lateral as a spot load and solved for as another single ladder network. Finally, all laterals are considered as spot loads on the primary feeder, and this ladder network is solved for.

In the ladder network load flow program used for all the simulations in this thesis, Equation (8.2) is expanded to include the complex and real components of the variables. Equation (8.2) is rewritten as:

$$V_n = V_S - I_i \left( \sum_{i=1}^n R_i + j \sum_{i=1}^n x_i \right) + \left[ \sum_{k=1}^{n-1} I_k \left( \sum_{i=k+1}^n R_i + j \sum_{i=k+1}^n x_i \right) \right] \quad (8.3)$$

where

$$I_i = \sum_{i=1}^{\text{total number of feeder buses}} I_i ,$$

$$I_k = \frac{[(V_i^r P_i + V_i^m Q_i) + j(V_i^m P_i - V_i^r Q_i)]}{(V_i^r)^2 + (V_i^m)^2},$$

$V_S$  is the substation voltage,

$V_i^r, V_i^m$  are the respective real and imaginary components of bus voltage  $i$ ,

$R_i$  is the resistance of section  $i$  of the feeder,

$x_i$  is the inductance of section  $i$  of the feeder,

$P_i$  is the real load at bus  $i$ , and,

$Q_i$  is the reactive load at bus  $i$ .

## 8.2.2 Load Sensitivity to Voltage

In order to investigate the load sensitivity to voltage, load modeling is incorporated into the ladder network load flow program. The power consumed by a load can be expressed as a function of the applied voltage:

$$S_L(V) = S + IV + \frac{V^2}{Z} \quad (8.4)$$

Equivalently, Equation (8.4) can be interpreted as a circuit consisting of a parallel connection of a constant power sink,  $S$ , a constant current sink,  $I$ , and a constant impedance,  $Z$ . Thus, for the load flow, the loads can be modeled as:

$$P = P_0(a_p + a_l V + a_z V^2) \quad (8.5)$$

$$Q = Q_0(b_q + b_l V + b_z V^2) \quad (8.6)$$

where  $a_p + a_l + a_z = 1$ ,  $b_q + b_l + b_z = 1$ , and  $P_0$  and  $Q_0$  are the respective real and reactive powers consumed by the load at the nominal voltage. Thus, using Equations (8.5) and (8.6), the loads can assume any voltage dependence by varying the coefficients. Unfortunately, there are no standard values for these parameters. The Independent Market Operator (IMO) of Ontario currently uses a 50% constant current and 50% constant impedance for real loads, and 100% constant impedance for reactive loads in their load flow studies (i.e.  $a_p = 0$ ,  $a_l = 0.5$ ,  $a_z = 0.5$ ,  $b_q = 0$ ,  $b_l = 0$ , and  $b_z = 1$ ) [80].

In the ladder network load flow program, after the voltages are updated by Equation (8.3), the loads are recalculated using Equations (8.5) and (8.6). Then using the newly calculated loads, the load currents drawn by the loads are calculated using Equation (8.1).

Having described the ladder network load flow program and the equations for load modeling, the next section provides a study of the effects of load modeling on losses and consumption. The results can aid to assess a utility's suitability for adopting CVR policies.

### **8.3 Load Model Studies**

Considering the same 34 bus system as used throughout this thesis, the following load model studies have been investigated:

- the relationship between losses and voltage reduction for various types of load models; and,
- the relationship between energy consumption and voltage reduction for various types of load models.

In the first study, as the voltage is decreased, losses are reduced if either the constant impedance model or the IMO model of 50% constant current and 50% constant impedance is used. There is hardly any change in loss using the constant current model. However, if the constant power model is used, the losses increase.

Figure 8.2 shows the effects of voltage reduction on losses for the various load models.

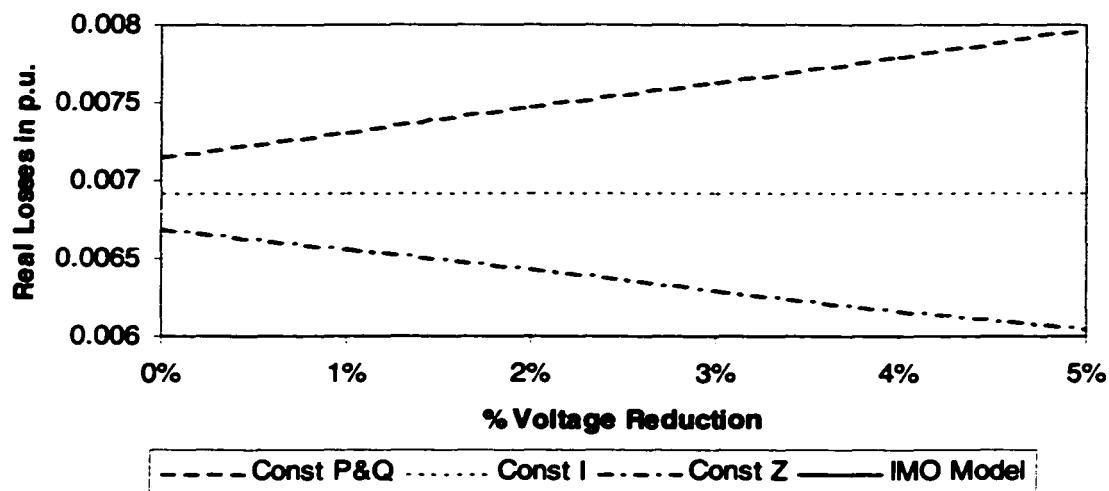

Figure 8.2: Voltage Reduction vs Losses for Various Load Models

As expected, similar results are found when comparing load consumption with voltage reduction. Consumption is reduced with voltage reduction for loads that are modeled as constant impedances or as the mixture used by the IMO. Using a constant current model also results in consumption reduction with declining voltages. And, in the case of using a constant power model, the load consumption increases a little. The effects of voltage reduction on load consumption are shown in Figure 8.3.

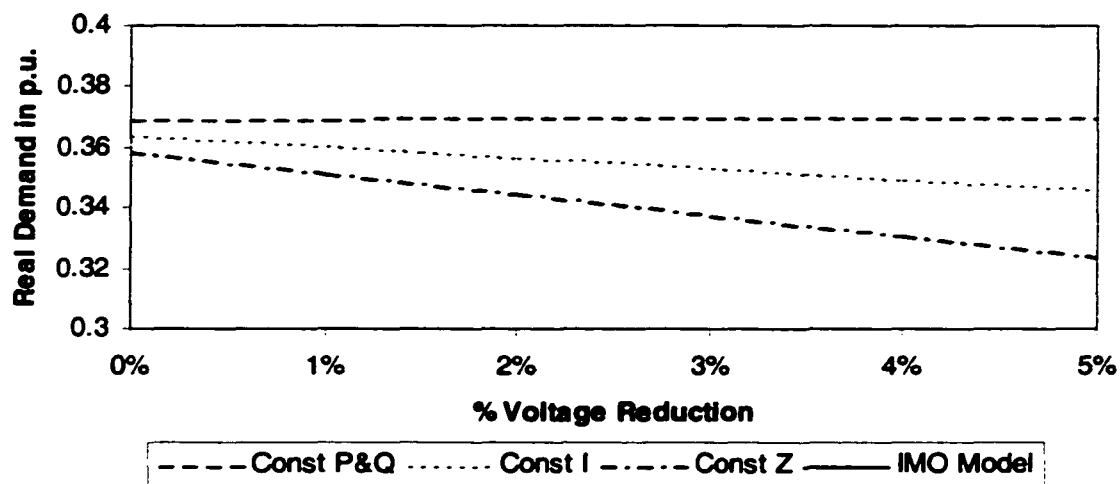

Figure 8.3: Voltage Reduction vs Demand for Various Load Models

The findings concur with the load model Equations (8.4) and (8.5). By inspection of these equations, as the voltage is reduced, the power also reduces for constant current and constant impedance models. Since a reduction in demand means a reduction in the load currents, the  $I^2R$  losses are also less.

Determining the composition of the distribution system loads is only one step in determining whether a CVR policy is feasible for a utility. First and foremost, a utility must ensure that their feeder voltages are at high enough levels before CVR is even considered. Since, an effect of capacitor placement is an improvement in the voltage profile, the next subsection explains how capacitor allocation can aid in the application of CVR.

### 8.3.1 Capacitor Allocation and the Application of CVR

Figure 8.4 shows the voltage profile of the 34 bus feeder with compensating capacitors during peak load.

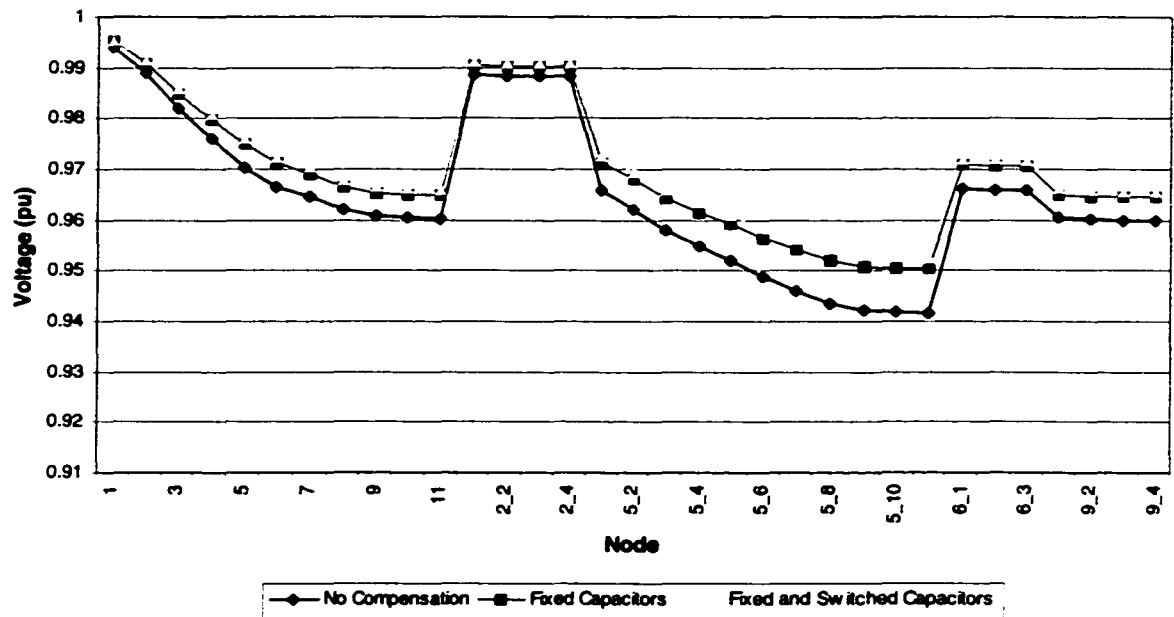

Figure 8.4: Voltage Profile of 34 Bus Feeder

This improvement of the voltage profile from the use of capacitors provides the utility with the option of practising CVR. Since the economics of capacitor installation have already been justified, any added benefits from CVR would be an extra saving for the utility. A quick load flow study can be performed to ensure that the feeder voltages are not too low for CVR and an investigation into the load mixtures of the system can further affirm the suitability of applying CVR. In the case

of the 34 bus system, it can be seen that with capacitor allocation, and using the load models specified by the IMO, CVR can certainly be applied.

In the case where the Detroit Edison Company [78] had reported that CVR was not deemed economically feasible, they had not mentioned doing any prior analysis to determine the load sensitivity to voltage reduction. Furthermore, voltage regulators were installed in the distribution circuit to improve the feeder voltage profiles to allow for the practice of CVR. Thus, it appeared that the economics of the project were determined after all the capital expenses were incurred. However, if a proper capacitor allocation scheme was applied to the system, such as the one described in this thesis, it would have been possible for the utility not to require voltage regulators before applying CVR.

In the future when Ontario's utilities will be in a deregulated environment, the demand charges will be eliminated and electricity will be sold by hourly usage. In such a deregulated environment, CVR can then be used for consumption control. One may argue that utilities would not favour CVR under the deregulated rate structure because a reduction in consumption would mean a reduction in revenues. However, in the growing concern for conservation of natural resources, some consumers would pay extra for energy from utilities who have a energy conservation philosophy in mind. In California, where the utility business was deregulated in 1998, there are some "green" electricity retailers who offer this service to consumers with conservation in mind [81]. By practising CVR, they reduce the consumption of the loads and market the energy at a higher price to consumers who are resource and energy conscious.

## **8.4 Summary**

The application of CVR may not be appropriate for all distribution systems. This chapter has introduced a load flow tool with a load modeling capability to aid in the assessment of implementing CVR. Despite any difficulty of determining the load models for the ladder network load flow program, a generic load model used by the IMO, of 50% constant current and 50% constant impedance for real loads and 100% constant impedance for reactive loads has been appropriate for systems in Ontario. In addition, with the implementation of a proper capacitor allocation, utilities can further perform CVR for additional loss savings without incurring the extra costs of installing voltage regulators. Even with the new rate design the utility business will adopt in the near future, consumption control via CVR can also be used as means for a utility to be labeled “green” to appeal to the energy conscious consumer.

## **9 Conclusions and Recommendations**

### **9.1 Conclusions**

This thesis has detailed a practical and flexible approach for distribution system loss reduction and performance enhancement. As identified in Chapter 2, capacitor placement requires minimal expenditure for implementation and is an effective method for loss reduction. Chapter 3 has critically reviewed much of the work done in the area of optimal capacitor placement and has cited many drawbacks of these previous methods. For many of these capacitor allocation techniques, the methods are often too general or inconvenient for practical application to a distribution system. Furthermore, much of the work did not include provisions for the placement and control of switched capacitors.

Chapters 6, 7, and 8 describe the key contributions of this thesis for distribution system loss reduction and performance enhancement. Namely, these are:

- the inclusion of fuzzy set theory to account for any uncertain or unavailable information, and to allow for interpretation of user decisions for improvement of system performance;
- the development of a FES to aggregate multiple objectives and to determine the best compromise solution for capacitor allocation;
- a complete capacitor allocation system that can be utilized for distribution system planning, expansion and operation;
- the identification of the importance of load modeling for CVR; and,
- the capability of incorporating the proposed method into a SCADA system.

As indicated in Chapter 4, FST can be a valuable tool in power system analysis. Fuzzy set theory allows for the modeling of data that is uncertain or even unavailable at all. In addition, FST can be used to represent information that is described in a linguistic manner. The proposed method has taken advantage of such values. The use of fuzzy inferencing has allowed for the identification of suitable locations for capacitor placement and also for the sizing of fixed and switched capacitors. The proposed method provides the user with a good interactive interface that conveys information in an easily understood linguistic manner.

The FES for capacitor planning can also be used for expansion purposes. For distribution system expansion, only the database of the load flow program needs to be updated with the expanded base case system. Operation of capacitors using the FES has already been shown. Thus, for the first time, a complete capacitor allocation system for distribution system planning, expansion and control is available.

The improvement of the voltage profile from proper capacitor placement and control can allow the utility the option of practising CVR. Several American utilities have practised CVR with varying degrees of success. However, there is no guideline available to determine whether CVR is beneficial to a utility. Chapter 8 has identified the importance of load modeling for loss calculation and suitability of CVR application. A ladder network load flow program which can consider any load model has also been provided to aid in loss and CVR studies.

This proposed method was developed using tools on the MS Windows platform. FuzzyClips was used as the FES shell, the ladder network load flow program was written and compiled in Borland C++, and the user-interface was developed using Visual Basic for applications. In the MS Windows environment, the advantages of Dynamic Data Exchange (DDE) and Object Link Embedding (OLE) allow the work of this thesis to be easily incorporated into any of the SCADA system software. Some of the popular SCADA packages include: FIX DMACS, Wonderware, and DACscan which all operate on the MS Windows platform.

The objectives of this thesis have been accomplished. However, several more components which are beyond the scope of this thesis can be added to further refine the system. The next section offers several recommendations for future work.

## **9.2 Recommendations for Future Work**

In order to perform proper distribution system planning, it is essential that a good load forecast is done. Many load forecasting techniques are available.

Nevertheless, to suit the fuzzy capacitor planning methods of this thesis, a fuzzy load forecasting technique where fuzzy loads are predicted would be ideal. The use of FST for load forecasting is highly appropriate, since load growth is non-stochastic in nature. Thus, it is only appropriate to assign fuzzy variables to load forecasting. To continue on this same theme, the load flow program used in this thesis accepts only crisp load information. A fuzzy load flow would further enhance this distribution system loss reduction scheme. The work of Miranda *et al.* [56, 57] on fuzzy load flows is well-suited for this application.

Conservative Voltage Regulation can be an effective means for further loss reduction. Chapter 8 has shown the effects of the various load models on loss reduction and consumption control. This study can be expanded to classify which load mixtures are the most ideal for the application of CVR. Such information can be organized into a fuzzy rule-based system to aid utilities in achieving their loss reduction goals.

## References

- [1] The Energy Competition Act, Bill 35, Government of Ontario, 1999.
- [2] *1990 Ontario Hydro Statistical Yearbook*, Ontario Hydro.
- [3] J.B. Bunch, R.D Miller, and J.E. Wheeler, "Distribution System Integrated Voltage and Reactive Power Control," *IEEE Trans. Power Apparatus and Systems*, vol. 101, no. 2, Feb. 1982, pp. 284-289.
- [4] Personal correspondence with Mr. S.L. Cress of Ontario Hydro Technologies.
- [5] Personal correspondence with Mr. P. Lo of Toronto Hydro Electric Commission.
- [6] S.L. Cress, *Economic Loading of Distribution Transformers*, Montreal, Canadian Electrical Association, 1993.

- [7] D.E. Bouchard, "Towards Loss Minimization in Power Distribution Systems using AI: the WatDist Algorithm," University of Waterloo Ph.D. Thesis, 1996.
- [8] R.B. Mason, "Switch over to savings: Toronto Hydro's switch to 13.8 kV saves money and trees," *Electrical Business*, vol. 31, no. 3, Mar. 1995, pp.12-13.
- [9] Personal correspondence with Mr. S.L. Cress of Ontario Hydro Technologies.
- [10] B. Williams and R. Krause, "Reducing Energy Consumption," *Transmission and Distribution*, Feb. 1994, pp. 58-60.
- [11] B.W.K. Kennedy and R.H. Fletcher, "Conservation Voltage Reduction (CVR) at Snohomish County PUD," *IEEE Trans. Power Systems*, vol. 6, no. 3, Aug. 1991, pp. 986-997.
- [12] H. Ng, "Power Distribution and the Information Highway," *Ontario Hydro Technologies*, Dec. 1996.
- [13] A. Dwyer, "The use of shunt capacitors applied for line loss savings," *Proc. 1992 CEA Conference*, April 1992.
- [14] W.M. Ritchie, P.W. Beard, A. Barker, and D.G.T. Lewis, "Loss Reduction – an overview of the problems and solutions," *Power Technology International*, 1988, pp. 191-194.
- [15] Capacitor Subcommittee of the IEEE Transmission and Distribution Committee, "Bibliography on Power Capacitors 1975-1980," *IEEE Trans. Power Apparatus and Systems*, vol. 102, no. 7, July 1983, pp. 2331-2334.

- [16] IEEE VAR Management Working Group of the IEEE System Control Subcommittee, "Bibliography on Reactive Power and Voltage Control," *IEEE Trans. Power Systems*, vol. 2, no. 2, May 1997, pp. 361-370.
- [17] N.M Neagle and D.R. Samson, "Loss Reduction from Capacitors Installed on Primary Feeders," *AIEE Trans.*, vol. 75, Oct. 1956, pp. 950-959.
- [18] R.F. Cook, "Analysis of Capacitor Application as Affected by Load Cycle," *AIEE Trans.*, vol. 78, Oct. 1959, pp. 950-957.
- [19] R.F. Cook, "Optimizing the Application of Shunt Capacitors for Reactive-Volt-Ampere Control and Loss Reduction," *AIEE Trans.*, vol. 80, Aug. 1961, pp. 430- 444.
- [20] J.V. Schmill, "Optimum Size and Location of Shunt Capacitors on Distribution Feeders," *IEEE Trans. Power Apparatus and Systems*, vol. 84, no. 9 , Sept. 1965, pp. 825-832.
- [21] N.E. Chang, "Locating Shunt Capacitors on Primary Feeder for Voltage Control and Loss Reduction," *IEEE Trans. Power Apparatus and Systems*, vol. 88, no. 10, Oct. 1969, pp. 1574-1577.
- [22] N.E. Chang, "Generalized Equations on Loss Reduction with Shunt Capacitors," *IEEE Trans. Power Apparatus and Systems*, vol. 91, 1969, pp. 1574-1577.
- [23] Y. G. Bae, "Analytical Method of Capacitor Allocation on Distribution Primary Feeders," *IEEE Trans. Power Apparatus and Systems*, vol. 97, no. 11, July/Aug. 1978, pp. 1232-1238.

- [24] T. Marx, *The Why and How of Power Capacitor Switching*, 2nd Printing, Fisher Pierce, Mar. 1991.
- [25] S.H. Lee and J.J. Grainger, "Optimum Placement of Fixed and Switched Capacitors on Primary Distribution Feeders," *IEEE Trans. Power Apparatus and Systems*, vol. 100, no. 1 Jan. 1981, pp. 345-352.
- [26] J.J. Grainger and S.H. Lee, "Optimum Size and Location of Shunt Capacitors for Reduction of Losses on Distribution Feeders," *IEEE Trans. Power Apparatus and Systems*, vol. 100, no. 3, Mar. 1981, pp. 1105-1118.
- [27] M.M.A. Salama, A.Y. Chikhani, and R. Hackam, "Control of Reactive Power in Distribution Systems with an End-Load and Fixed Load Conditions," *IEEE Trans. Power Apparatus and Systems*, vol. 104, no. 10, Oct. 1985, pp. 2779-2788.
- [28] M.M.A. Salama, E.A.A. Mansour, A.Y. Chikhani, and R. Hackam, "Control of Reactive Power in Distribution Systems with an End-Load and Varying Load Conditions," *IEEE Trans. Power Apparatus and Systems*, vol. 104, no. 4, Apr. 1985, pp. 941-947.
- [29] J.J. Grainger and S. Civanlar, "Volt/Var Control on Distribution Systems with Lateral Branches Using Shunt Capacitors and Voltage Regulators, Part I: The Overall Problem," *IEEE Trans. Power Apparatus and Systems*, vol. 104, no. 11, Nov. 1985, pp. 3278-3283.

- [30] S. Civanlar and J.J. Grainger, "Volt/Var Control on Distribution Systems with Lateral Branches Using Shunt Capacitors and Voltage Regulators, Part II: The Solution Method," *IEEE Trans. Power Apparatus and Systems*, vol. 104, no. 11, Nov. 1985, pp. 3284-3290.
- [31] S. Civanlar and J.J. Grainger, "Volt/Var Control on Distribution Systems with Lateral Branches Using Shunt Capacitors and Voltage Regulators, Part III: The Numerical Results," *IEEE Trans. Power Apparatus and Systems*, vol. 104, no. 11, Nov. 1985, pp. 3291-3297.
- [32] H. Duran, "Optimum Number, Location, and Size of Shunt Capacitors in Radial Distribution Feeders, A Dynamic Programming Approach," *IEEE Trans. Power Apparatus and Systems*, vol. 87, no. 9, Sept. 1968, pp. 1769-1774.
- [33] T.H. Fawzi, S.M. El-Sobki, and M.A. Abdel-Halim, "New Approach for the Application of Shunt Capacitors to the Primary Distribution Feeders," *IEEE Trans. Power Apparatus and Systems*, vol. 102, no. 1 Jan. 1983, pp. 10-13.
- [34] M. Ponnavaikko and K.S. Prakasa Rao, "Optimal Choice of Fixed and Switched Shunt Capacitors on Radial Distributors by the Method of Local Variations," *IEEE Trans. Power Apparatus and Systems*, vol. 102, no. 6, June 1983, pp. 1607-1615.
- [35] M.E. Baran and F.F. Wu, "Optimal Capacitor Placement on Radial Distribution Systems," *IEEE Trans. Power Delivery*, vol. 4, no. 1, Jan. 1989, pp. 725-734.

- [36] M.E. Baran and F.F. Wu, "Optimal Sizing of Capacitors Placed on a Radial Distribution System," *IEEE Trans. Power Delivery*, vol. 4, no. 1, Jan. 1989, pp. 735- 743.
- [37] R. Baldick and F.F. Wu, "Efficient Integer Optimization Algorithms for Optimal Coordination of Capacitors and Regulators," *IEEE Trans. Power Systems*, vol. 5, no. 3, Aug. 1990, pp. 805-812.
- [38] S. Civanlar, J.J. Grainger, H. Yin, and S.H. Lee, "Distribution Feeder Reconfiguration for Loss Reduction," *IEEE Trans. Power Delivery*, vol. 3, no. 3, July 1988, pp. 1217-1223.
- [39] T. Taylor and D. Lubkeman, "Implementation of Heuristic Search Strategies for Distribution Feeder Reconfiguration," *IEEE Trans. Power Delivery*, vol. 5, no. 1, Jan. 1990, pp. 239-246.
- [40] T.S. Abdel-Salam, A.Y. Chikhani, and R. Hackam, "A New Technique for Loss Reduction Using Compensating Capacitors Applied to Distribution Systems with Varying Load Condition," *IEEE Trans. Power Delivery*, vol. 9, no. 2, Apr. 1994, pp. 819-827.
- [41] M. Chis, M.M.A. Salama, and S. Jayaram, "Capacitor Placement in Distribution Systems Using Heuristic Search Strategies," *IEE Proceedings Generation, Transmission and Distribution*, vol. 144, no. 2, May 1997, pp. 225-230.

- [42] G. Boone and H.D. Chiang, "Optimal capacitor placement in distribution systems by genetic algorithm," *Electrical Power & Energy Systems*, vol. 15. no. 3, 1993. pp. 155-162.
- [43] S. Sundhararajan and A. Pahwa, "Optimal Selection of Capacitors for Radial Distribution Systems Using a Genetic Algorithm," *IEEE Trans. Power Systems*, vol. 9. no. 3, Aug. 1994. pp. 1499-1507.
- [44] K.N. Miu, H.D. Chiang, and G. Darling, "Capacitor Placement, Replacement and Control in Large-Scale Distribution Systems by a GA-Based Two-Stage Algorithm," *IEEE Trans. Power Systems*, vol. 12, no. 3, Aug. 1997, pp. 1160-1166.
- [45] C. C. Liu, T. Dillon, "State-of-the-art of expert system applications to power systems", *Electrical Power & Energy Systems*, vol. 14, no. 2, 1992, pp. 86-92.
- [46] M.M.A. Salama and A.Y. Chikhani, "An Expert System for Reactive Power Control of a Distribution Systems, Part 1: System Configuration," *IEEE Trans. Power Delivery*, vol. 7, no. 2, Apr. 1992, pp. 940-945.
- [47] J.R.P.R. Laframboise, G. Ferland, A.Y. Chikhani, and M.M.A. Salama, "An Expert System for Reactive Power Control of a Distribution System, Part 2: System Implementation," *IEEE Trans. Power Systems*, vol. 10, no. 3, Aug. 1995, pp. 1433- 1441.
- [48] T. Ananthapadmanabha, A.D. Kulkarni, A.S. Gopala Rao, and K. Raghavendra Rao, "Knowledge-based expert system for optimal reactive power control in

- distribution system,” *Electrical Power & Energy Systems*, vol. 18, no. 1, 1996, pp. 27-31.
- [49] N.I. Santoso and O.T. Tan, “Neural-Net Based Real-time Control of Capacitors Installed on Distribution Systems,” *IEEE Trans. Power Delivery*, vol. 5, no. 1, Jan. 1990, pp. 266-272.
- [50] Z. Gu and D.T. Rzy, “Neural Networks for Combined Control of Capacitor Banks and Voltage Regulators in Distribution Systems,” *IEEE Trans. Power Delivery*, vol. 11, no. 4, Oct. 1996, pp. 1921-1928.
- [51] L.A. Zadeh, “Fuzzy Sets,” *Information and Control*, vol. 8, no. 3, 1965, pp. 338-353.
- [52] H.C. Chin, “Optimal shunt capacitor allocation by fuzzy dynamic programming,” *Electric Power Systems Research*, vol. 35, 1995, pp. 133-139.
- [53] I.P. Thurein, “Adequacy of system security assessment for system operators,” *Proc. CIGRE 1986 Session*, Paris, France, 1986, paper 39-02.
- [54] T.J. Ross, *Fuzzy logic with engineering applications*, New York: McGraw-Hill, 1995.
- [55] R. Kruse, J. Gebhardt, and F. Klawonn, *Foundations of fuzzy systems*, New York: Wiley & Sons, 1994.
- [56] V. Miranda and M.A. Matos, “Fuzzy load flow – new algorithms incorporating uncertain generation and load representation,” *Proc. 10<sup>th</sup> PSCC*, 1990, pp. 621-627.

- [57] V. Miranda and J.T. Saraiva, "Fuzzy Modeling of Power System Optimal Power Flow," *IEEE Trans. Power Systems*, vol. 7 no. 2, May 1992, pp. 843-849.
- [58] Y.Y. Hsu and K.L. Ho, "Fuzzy expert systems: an application to short term load forecasting," *IEE Proceedings – C*, vol. 139, no. 6, Nov. 1992, pp. 471-477.
- [59] J.T. Saraiva, V. Miranda, and L.M.V.G. Pinto, "Impact on some planning decisions from a fuzzy modeling of power systems," *Proc. PICA*, 1993, pp. 327-333.
- [60] R. Yokoyama, T. Niimura, and Y. Nakanishi, "A coordinated control of voltage and reactive power by heuristic modeling and approximate reasoning," *IEEE Trans. Power Systems*, vol. 8, no. 2, May 1993, pp. 636-645.
- [61] C.J. Kim and B.D. Russell, "A Structure of Fuzzy Decision-Making System for Power System Protection," *Proc. 1993 Conference on Fuzzy Systems*, San Francisco, 1993, pp. 998-1003.
- [62] L.A. Zadeh, "Outline of a new approach to analysis of complex systems and decision processes," *IEEE Trans. Systems Man and Cybernetics*, vol. 3, no. 1, Jan. 1973, pp. 28-44.
- [63] Ontario Hydro Voltage Standards for Distribution Supply Systems, No. 87-3 DP, Aug. 1987.
- [64] R.A. Orchard, *FuzzyCLIPS Version 6.04 User's Guide*, National Research Council Canada, June 1995.

- [65] E.H. Mamdani, "Application of fuzzy algorithms for control of simple dynamic plant," *Proc. IEEE*, vol. 121, no. 12, pp.1585-1588, 1976.
- [66] T. Gonen, *Electric Power Distribution System Engineering*, McGraw-Hill, 1986.
- [67] Westinghouse Electric Corporation, *Electric Utility Engineering Reference Book – Distribution Systems*, vol. 3, East Pittsburgh, PA, 1965.
- [68] F.H. Buller and C.A. Woodrow, "Load Factor – Equivalent Hour Values Compared," *Electrical World*, vol. 92, no. 2, July 14, 1928, pp. 59-60.
- [69] T. Takagi and M. Sugeno, "Fuzzy Identification of Systems and It's Application to Modeling and Control," *IEEE Trans. Systems, Man, and Cybernetics*, vol. 15, no.1, Jan./Feb. 1985, pp. 116-132.
- [70] J. Marks, "New, low-cost radios control capacitors, enable SCE to expand distribution automation," *Electrical World*, Aug. 1995, pp. 49-50.
- [71] R.M. Godfrey and P. Robiou, "Survey of Current Applications of Distribution Automation in North America," *CEA Report*, no. 039 D 884, Oct. 1993.
- [72] Y.Y Hsu and H.C. Kuo, "Dispatch of capacitors on distribution system using dynamic programming," *IEE Proceedings-C*, vol. 140, no. 6, Nov. 1993, pp. 433-438.
- [73] M.M.A. Salama, N. Manojlovic, and V.H. Quintana, "Real-time optimal reactive power control for distribution networks," *Electrical Power & Energy Systems*, vol. 18, no. 3, 1996, pp. 185-193.
- [74] Ontario Hydro Distribution Technical Guide, Section 21. Jan. 1980.

- [75] T.P. Wagner, A.Y. Chikhani, and R. Hackam, "Feeder Reconfiguration for Loss Reduction: An Application of Distribution Automation," *IEEE Trans. Power Delivery*, vol. 6, no. 4, 1991, pp. 1992-1931.
- [76] J.G. De Stesse, S.B. Merrick, and B.W. Kennedy, "Estimating Methodology for a Large Regional Application of Conservation Voltage Reduction," *IEEE Trans. Power Systems*," vol. 5, no. 3, Aug. 1990, pp. 862-868.
- [77] B. Burrows and G. Gurlaskie, "An Aid For Managing Demand," *Transmission and Distribution*, Feb. 1994, pp. 53-57.
- [78] T. J. Krupa and H. Asgeirsson, "The Effects of Reduced Voltage on Distribution Circuit Loads," *IEEE Trans. Power Systems*, vol. 2, no. 4, Nov. 1987, pp. 1013-1018.
- [79] C.B. Brice, "A Comparison of Approximate and Exact Voltage Drop Calculation for Distribution Lines," *IEEE Trans. Power Systems*, vol. 101, 1982, pp. 4428-4431.
- [80] Personal correspondence with Dr. C. Tang of the Independent Electricity Market Operator.
- [81] Information from [www.energycentral.com](http://www.energycentral.com).