

Microgrid Modeling for Stability Analysis

IEEE-PES Task Force on Microgrid Dynamic Modeling

Chairman: Claudio A. Cañizares Secretary: Rodrigo Palma-Behnke

Contributors: Danny Espín-Sarzosa, *Member IEEE*, Rodrigo Palma-Behnke, *Senior Member IEEE*, Claudio A. Cañizares, *Fellow IEEE*, Udaya Annakkage, *Senior Member IEEE*, Marcelo Elizondo, *Senior Member IEEE*, Enrique Espina, *Senior Member IEEE*, Wei Du, *Member IEEE*, Mahmoud Kaban, *Member IEEE*, Lasantha Meegahapola, *Member IEEE*, Patricio A. Mendoza-Araya, *Member IEEE*, Ehsan Nasr, *Senior Member IEEE*, Ahda Pavani, *Senior Member IEEE*, Rodrigo Ramos, *Senior Member IEEE*, Michael Ropp, *Senior Member IEEE*, Kevin P. Schneider, *Fellow IEEE*, John W. Simpson-Porco, *Senior Member IEEE*, Kai Strunz, *Senior Member IEEE*, Glauco Taranto, *Senior Member IEEE*, Francis Tuffner, *Member IEEE*, and James T. Reilly, *Member IEEE*

Abstract—This document is a summary of a report prepared by the IEEE PES Task Force (TF) on Microgrid (MG) Dynamic Modeling, IEEE Power and Energy Society, Tech. Rep. PES-TR106, 2023. In this paper, the major issues and challenges in microgrid modeling for stability analysis are discussed, and a review of state-of-the-art modeling approaches and trends is presented. In the context of the IEEE 1547 standard, the document covers issues associated with component models for MG dynamic studies and simulations, including generator and grid modeling, full and average converter models, unbalanced and balanced system conditions, dynamic and static loads, protection requirements, and detailed and simplified controls considering communications delays, packet losses, and security issues. Considering the future integration of grids and MGs to form broad integrated networks, a discussion is presented of the use of phasor vis-à-vis electromagnetic transient simulation tools for MG dynamic stability studies, as well as modeling scale-up issues and MG equivalent models. Specifically white-, grey-, and black-box models, are presented. This TF paper and companion report constitute a modeling guide for R&D groups working on developments and standards of MGs with a focus on stability issues.

Index Terms—Computational burden, dynamics, electromagnetic transient simulation, microgrid, modeling, power system control, power control protection, simulation tools, stability.

LIST OF ACRONYMS

ADN	Active Distribution Network
ANN	Artificial Neural Network
AVM	Average-Value Model
BESS	Battery Energy Storage System
BPS	Bulk Power Systems
CHIL	Control Hardware in the Loop
CPL	Constant Power Load
DEM	Detailed Equivalent Model
DER	Distributed Energy Resource
DFIG	Doubly-Fed Induction Generator
DG	Distributed Generation
DOL	Direct On-Line
EMS	Energy Management System
EMT	Electromagnetic Transients
ESS	Energy Storage System
EV	Electric Vehicle

The work of the IEEE PES Task Force (TF) on Microgrid (MG) Dynamic Modeling, has been sponsored by the PES Power System Stability Subcommittee of PES Power System Dynamic Performance Committee.

D. Espín-Sarzosa is with the Escuela de Ingeniería Eléctrica, Pontificia Universidad Católica de Valparaíso (e-mail: danny.espin@pucv.cl).

R. Palma-Behnke and P. A. Mendoza-Araya are with the Department of Electrical Engineering, Energy Center, University of Chile, Santiago, Chile (e-mail: rodpalma@cec.uchile.cl; pmendoza@ing.uchile.cl).

C. A. Cañizares is with the Department of Electrical and Computer Engineering, University of Waterloo, Waterloo, Ontario, Canada (e-mail: ccanizares@uwaterloo.ca).

U. Annakkage is with the Department of Electrical and Computer Engineering, University of Manitoba, Winnipeg, Canada (e-mail: udaya.annakkage@umanitoba.ca).

M. Elizondo, W. Du, F. Tuffner and K. P. Schneider are with the Pacific Northwest National Laboratory (PNNL), Richland, Washington, USA (e-mail: marcelo.elizondo@pnnl.gov; wei.du@pnnl.gov; francis.tuffner@pnnl.gov; kevin.schneider@pnnl.gov).

E. Espina is with the Department of Electrical Engineering, University of Santiago of Chile, Santiago, Chile (e-mail: enrique.espinag@usach.cl).

M. Kaban is with the School of Engineering, University of St. Thomas, Minnesota, USA (e-mail: mahmoud.kaban@stthomas.edu).

L. Meegahapola is with the Electrical and Biomedical Engineering Department, RMIT University, Melbourne, Victoria, Australia (e-mail: lasantha@ieee.org).

E. Nasr is with Microsoft, Redmond, Washington, USA (e-mail: ehsan.nasr@microsoft.com).

A. Pavani is with the Center for Engineering, Modeling and Applied Social Sciences, Federal University of ABC, São Paulo, Brazil (e-mail: ahda.pavani@ufabc.edu.br).

R. Ramos is with the Department of Electrical Engineering, University of Sao Paulo, Sao Paulo, Brazil (e-mail: rodrigo.ramos@ieee.org).

M. Ropp is with Sandia National Laboratories, Albuquerque, New Mexico, USA (e-mail: meropp@sandia.gov).

J. W. Simpson-Porco is with the Department of Electrical and Computer Engineering, University of Toronto, Toronto, O, Canada (e-mail: jwsimpson@ece.utoronto.ca).

K. Strunz is with the Department of Electrical Engineering and Computer Sciences, Technical University of Berlin, Berlin, Germany (e-mail: kai.strunz@tu-berlin.de).

G. Taranto is with the Federal University of Rio de Janeiro - COPPE, Rio de Janeiro, Brazil (e-mail: glaucotaranto@coppe.ufrj.br).

J. T. Reilly is with Reilly Associates, New Jersey, USA (e-mail: j_reilly@verizon.net)

FAST	Frequency-adaptive Simulation of Transients
FC	Fuel Cell
GFL	Grid-Following
GFM	Grid-Forming
GSC	Grid Side Converter
HELICS	Hierarchical Engine for Large-scale Infrastructure Co-Simulation
IBR	Inverter-Based Resources
IM	Induction Motor
INR/I	Incremental Negative Resistance or Impedance
MG	Microgrid
MPPT	Maximum Power Point Tracking
MOR	Model Order Reduction
PCC	Point of Common Coupling
PEC	Power Electronic Converter
PLL	Phase-Locked Loop
PV	Photovoltaic
RNNs	Recurrent Neural Networks
RSC	Rotor Side Converter
SG	Synchronous Generator
SMPS	Switch-Mode Power Supplies
SoS	Systems of Systems
TF	Task Force
UTP/STP	Unshielded/Shielded Copper Twisted Pairs
VFD	Variable Frequency Drive
VSCs	Voltage Source Converters
VSG	Virtual Synchronous Generator
VSIs	Voltage Source Inverters
WECC	Western Electricity Coordinating Council
ZIP	Constant impedance, Z, constant current, I, and constant power, P, loads

I. INTRODUCTION

THE modeling and computational requirements to represent in detail various system elements and conditions to properly study stability in Microgrids (MGs) could be very onerous, requiring certain computational tools that restrict the types of studies that can be performed, thus limiting dynamic simulations to a few seconds for a reduced number of MG components. Moreover, model approximations that reduce the computational burden and may be able to efficiently represent certain dynamic phenomena in MGs might not be sufficient to fully analyze the stability of these systems. In this context, this document summarizes the detailed IEEE PES Task Force (TF) report [1], which focuses on studying and determining the validity and types of applications of detailed and approximate component models for MG dynamic studies and simulations for stability analysis, in the context of the IEEE 1547 standard.

The structure of modern power systems is transitioning from a centralized one, where bulk generation supplies loads through transmission and distribution system infrastructure, to a more complex grid, which incorporates decentralized self-sufficient low-voltage grids with Distributed Energy Resources (DERs) that can form MGs. These DERs, which include diesel generators as well as Inverter-Based Resources (IBRs), such as Photovoltaic (PV) generation, small natural-gas-based generators, controllable loads, Energy Storage Systems (ESSs), and Electric Vehicles (EVs), not only have the capability of exchanging

power with the grid, but can also provide grid services, such as voltage and frequency regulation, and improve system stability, which are essential when MGs operate in islanded mode. Furthermore, concerns about the security of supply, power quality issues, and grid resilience, accompanied by dropping prices of PV systems and Battery ESSs (BESSs), are resulting in new MGs being formed and embedded in distribution grids, which have the potential to impact the grids where they are connected. For example, the direction and magnitude of the power exchange at the Point of Common Coupling (PCC) with the grid can rapidly change depending on the MG's own requirements. Finally, IBRs embedded in MGs do not contribute inertial response to the MG and main grid, affecting the stability of these systems. Hence, understanding the dynamic behavior of MGs, which act as single controllable entities at their respective PCC, and their impact and interaction with the grid, is becoming essential for grid operators and planners, requiring appropriate modeling approaches.

The final report and associated paper of the IEEE PES TF entitled "MG Stability Definitions, Analysis, and Modeling" define concepts and identify relevant issues related to stability in MGs [2], [3]. These documents propose definitions and a classification of MG stability, considering important differences in MGs compared to Bulk Power Systems (BPS) relevant to stability, such as smaller system size, higher penetration of RES, higher uncertainty, lower system inertia, higher R/X ratio of the feeders, limited short-circuit capacity, and unbalanced three-phase loading [2], [3]. These documents discuss systemic differences between MGs and conventional BPS, identifying new types of stability issues in MGs. For example, in conventional systems, transient and voltage stability problems typically occur more often than frequency stability ones, whereas in isolated/islanded MGs, maintaining frequency stability is more challenging due to the low system inertia and a high share of variable RES. In addition, some stability problems observed in large interconnected systems, such as inter-area oscillations and voltage collapse, have not been observed in MGs. References [2], [3] also conclude that the models of the different components of a MG have a significant impact on the simulation and associated results of dynamic events in these systems. Hence, to address these challenges, a TF on MG Modeling for Stability Analysis was created, focusing on various relevant aspects of ac MG dynamic studies and simulations for stability studies, in the context of the IEEE Std. 1547 series [4]. This paper can be considered as a guideline for choosing the appropriate modeling approach depending on the particular study needs.

Based on the aforementioned modeling aspects, this document comprises multiple sections that discuss MG equipment and system dynamic models, including controls and communications, and modeling techniques and analysis tools to capture the stability characteristics in MGs from different perspectives and approaches. It is important to mention the presented models have been specifically researched to address the required modeling accuracy for stability studies highlighted in [3] and in Section 4 of [2].

In this context, this work starts with a historical perspective in Section II, providing a comprehensive overview of the existing technical literature on the topic and main related trends. Section III presents generator and grid models for MG stability studies, while Section IV reviews relevant converter modeling

aspects, and Section V discusses load modeling approaches. In Section VI, control and communication modeling and associated issues relevant to MG stability are reviewed, and Section VII describes relevant modeling tools for MG stability analysis. Section VIII presents different modeling scale-up approaches that may be used for MG stability analysis, especially in the context of large interconnected MG systems, Section IX reviews and describes the system equivalent models of MGs for their stability analysis from a system interconnection perspective, and Section X outlines the challenges associated with MG modeling for protection design and lays out a set of requirements for associated design tools. Finally, Section XI highlights the main contributions and conclusions of the TF work.

II. HISTORICAL PERSPECTIVE

The technical challenges of operating more than one DER in an islanded mode have been evident since the early years of MG stability research [5]. Thus, small-perturbation models were developed to study the dynamic behavior of these systems based on eigenvalue analyses, and guidelines were provided in 2008 for the design of controllers that met the IEEE P1547 performance specifications [4]. In this context, there are currently several complementary standards related to the interconnection and interoperability of distributed energy resources. For example, IEEE 1547.1 describes testing procedures for interconnection compliance [6]. The remaining complementary standards cover cyber-security guidelines, design and operation of conforming systems, secondary network interconnections, distribution impact studies, and energy storage guidelines.

Control strategies were one of the main issues discussed in the technical literature in 2009. Supervisory and control systems were classified into centralized and decentralized in [7], and unbalanced operation, harmonic distortion, and computational burden were identified as aspects that should be considered for stability and control studies in [8].

With the developments in MGs, published work moved beyond optimizing the dispatch of a number of generators and loads toward the optimization of numerous micro sources/storage, as well as the coupling with heat and gas. Thus, in [9], issues associated with grid-connected and islanded operation were analyzed, as these are likely to produce large power balance mismatches, causing severe frequency and voltage control problems in MGs. Furthermore, “plug-and-play” capabilities were also identified as a source for serious stability issues with the possible and concurrent connection/disconnection of a large number of micro sources.

With the consideration of the unique characteristics of solar PV sources and wind turbines, the validity of conventional small-perturbation stability models based on local linearization was questioned in [10]. Moreover, as discussed in [11], while the impact of load characteristics on MG stability is quite evident, it was not until 2012 that concerns were reported regarding load modeling. Also, in [12], stability analyses were carried out for the four modes of MG operation, identified in the IEEE Std. 1547.4-2011 [13], i.e., connected mode, transition-to-island mode, island mode, and reconnection mode.

Reference [14] investigated in 2013 different stability issues with MGs depending on the application. Thus, it was noted that the MG structure and the control topology vary depending on the application, hence affecting system stability. Stability

studies of various types of MGs were presented for different controls using eigenvalue analyses and time domain simulations. A state-space model was used for modeling DERs and loads, primarily using Lyapunov function techniques for stability studies, and discussing modeling alternatives to improve system stability.

In [15], a summary of MG modeling and control, as well as the relevance of incorporating MGs into the existing grid were discussed in 2014. The need for full dynamic modeling of the complete network was examined, comprising inverters, network, and loads, and considering various options for modeling DERs and converter interfaces. Matlab and ATPDraw simulation tools were used for the presented dynamic studies.

In 2015, [16] presented a summary of four different methods used/proposed for stability analysis of power converters, and the increasing complexity of converter topologies was highlighted as a challenge that required attention. In [17], several MG architectures, models, and control schemes were summarized, applying the concept of System of Systems (SoS) to MGs, as these are integrated systems with heterogeneous and independently operable systems, networked together for cost effectiveness, robustness, and better performance. Moreover, the stability of the communication network connecting the Distributed Generation (DG) units and inverters was also discussed.

In 2016, [18] reviewed state-of-the-art analytical methods used for stability analysis of MGs, including eigenvalue analyses based on state-space models, impedance-based approaches, and other nonlinear system analysis techniques, discussing their respective advantages and disadvantages. In [19], an extensive literature survey on several stability issues in MGs was presented, and in [20], a classification of MG stability, which considers the MG operating mode, types of disturbances, and time frames, was proposed. The latter also presented a comprehensive review of the literature on MG stability, mentioning that stability studies have been primarily based on simulation tools (e.g., DIGSILENT, PSCAD, and Matlab), but that further research on theoretical approaches was needed. Finally, the authors in [21] reviewed the key characteristics and main components of a MG, such as standard operating modes and control schemes of IBRs.

In 2017, [22] presented a survey of Lyapunov-based large-perturbation stability studies of MGs, discussing also large-perturbation analyses of individual generator and load types in the context of MGs, as well as stability studies of dc/ac droop-controlled inverters, ac/dc and dc/dc converters, and motor drives. Reference [23] provided a comprehensive review of load dynamic models in MGs, such as Constant Power Load (CPL) and Incremental-Negative Resistance or Impedance (INR/I) models, and their dynamic behavior, as well as an analysis of compensation methods to stabilize MGs with CPLs.

Based on the existing literature and the state-of-the-art on MG stability in 2018, the IEEE PES Task Force on MG Stability, Definitions, Analysis, and Modeling defined and classified MG stability in [2], summarizing later the report in [3]. Besides the definitions and classification for MG stability, the report presented a general discussion of models of MG components in the context of stability studies, as well as an overview of analysis techniques and tools. The same year, a comprehensive review of research work on stabilization of ac MGs with CPLs

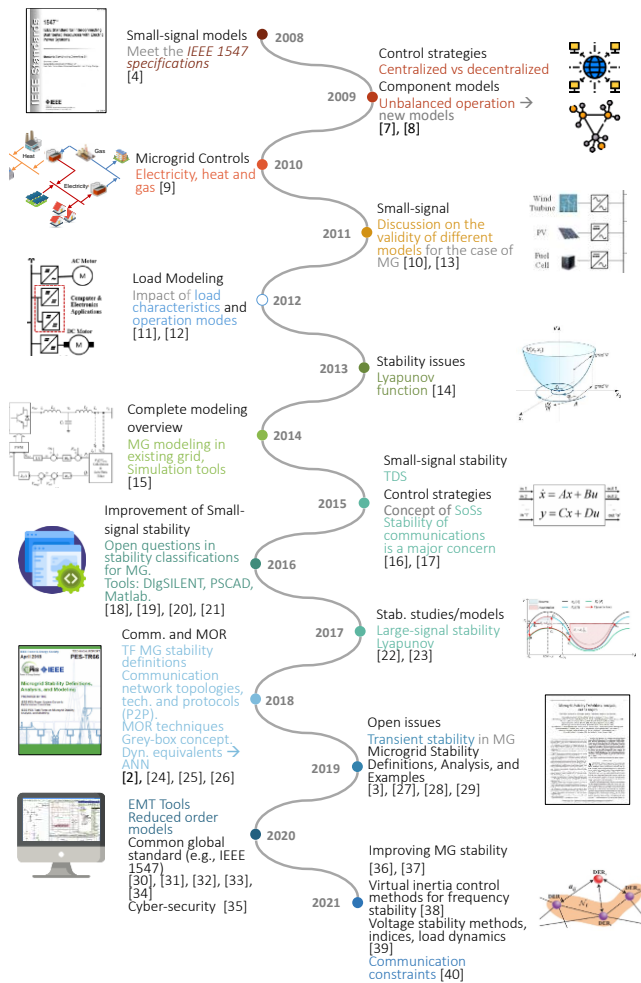

Fig. 1 Evolution of MG modeling topics for stability analysis. Different colors are used to identify the year the highlighted topic first appeared.

was presented in [24], which also reviewed several tools for stability analysis, such as Matlab/Simulink, PSCAD/EMTDC, and others. Reference [25] presented a comprehensive survey for existing MG models and their principles and applicability, together with stochastic and predictive modeling, and a classification of various modeling techniques under four categories: component-wise, single entity/lumped, stochastic/predictive, and dynamic equivalency. Lower-order models obtained from Model Order Reduction (MOR) techniques and dynamic equivalent models such as black-box, grey-box, and Artificial Neural Networks (ANNs) were also discussed. Lastly, [26] provided a systematic review of the most suitable communication network topologies, technologies, and protocols for MGs, concluding that a new generation of Peer-to-Peer communication systems would be required in smart MGs; potential research on communications for the next generation of MGs was also discussed.

In 2019, [27] summarized the definitions, classifications, and characteristics of MGs for researchers working on MGs, and highlighted the fact that although large-disturbance issues have been extensively studied in large power systems, these types of studies for MGs were limited. Furthermore, the need for additional research in MG stability analysis considering characteristics such as mesh networks, nonlinear loads such as induction motors (IMs), CPLs, EVs, and others, and various controls for power converters was discussed. In the same year,

a comprehensive review of the control methods used in transient stability of MGs and their advantages and disadvantages was presented in [28]. Finally, an overview of small-perturbation modeling challenges was presented in [29], summarizing, and analyzing the most challenging topics in MG modeling, and explaining and providing a timeline of small-perturbation modeling methods for MGs.

During 2020, various publications discussed current topics and challenges in MG stability. Thus, in [30], an overview of different approaches for the provision of virtual inertia was presented, along with a detailed description of Virtual Synchronous Generators (VSGs), discussing methods for its stability analysis such as small-perturbation and transient stability techniques. The authors in [31] presented a comprehensive literature review of the main design features of existing MGs, as well as the main control functions that are required to ensure their economic, reliable, and secure operation in different operating modes. Several other topics were also identified, particularly the use of time domain simulators for MG dynamic security assessment, the need for accurate and computationally efficient dynamic models, and the upgrade of existing protection schemes to adaptive protection schemes. A comprehensive review and assessment of reduced-order models for small-perturbation stability studies of MGs was presented in [32], and in [33], an overview was provided for large-disturbance stability analysis of MGs dominated by power converters, discussing their characteristics and the technical challenges associated with using conventional and Lyapunov-based methods for stability studies. Additionally, in [34], the authors identified the need to define a common global regulatory framework and standards for DERs and MGs, since the current available standards have significant differences among them. Finally, in [35], cyber-attacks were identified as a relevant issue as they can negatively affect MG stability and operation, providing a review of cyber-attacks in the MG context, and standards and protocols associated with MG cyber-security.

In 2021, [36] and [37] summarized methods, techniques, and strategies to improve stability in MGs. In [37] in particular, the need for future research focused on the effects on MG stability due to the presence of different types of loads and uncertain conditions was mentioned. Reference [38] presented a summary of the MG control methods suitable for different scenarios from the perspective of frequency stability, the associated open theoretical and numerical challenges, and the predominant control strategies, reviewing studies related to inertia control methods in islanded MGs. The authors in [39] provided a comprehensive review on voltage stability of MGs considering topics such as voltage stability of autonomous MGs, impact of inter-linking converters, coordination of voltage control loops, load dynamics on voltage stability, methods of static and dynamic analysis for determining voltage stability, and voltage stability indices for MGs. Finally, the influence of communication constraints on the stability of MGs was discussed in [40], providing a survey of cyber-enabled distributed control techniques for MG secondary control; the need for considering multiple communication constraints on MG stability is also highlighted in this work.

Fig. 1 summarizes the evolution of MG modeling topics for stability analysis, based on the aforementioned review of the existing literature on the topic. The diagram illustrates the

chronological perspective of the main trends in MG modeling for stability analysis, summarizing specific topics in the existing literature relevant to the TF scope.

Based on the aforementioned historical evolution review, the following trends and main issues related to MG modeling for stability analysis can be identified:

- It has been observed that generator and grid models need to consider the particular characteristics of MGs such as unbalanced operation, R/X ratio, radial network topologies, and relevance of system frequency variance among others.
- A variety of models and control strategies of power converters have been proposed for MGs. In this context, the need of a systematization of these models and control strategies for MG stability analysis has been identified. For example, proper interfaces and models of various converter topologies for wind generation, photovoltaic plants, ESSs, and fuel cells under unbalanced conditions are needed.
- The accurate representation of loads has been recognized as a relevant aspect for the proper characterization and analysis of MG dynamics and stability. In this context, specialized load models such as static, dynamic, composite, and Power Electronic Converter (PEC)-interfaced models are required, as well as load modeling approaches such as component-based and measurement-based.
- Control and communication interfaces have been identified as relevant for stability analysis of MGs (e.g., controller sampling rates and communication delays). For secondary control implementations, centralized and decentralized architectures have been adopted, with a clear trend to adopt decentralized architectures because these address single-point-of-failure issues; however, further understanding is needed of whether decentralized alternatives are feasible and appropriate beyond frequency and voltage regulation.
- The need for appropriate modeling tools for voltage and frequency stability analysis in MGs have been identified. In this context, a unified approach for phasor and Electro Magnetic Transient (EMT)-type modeling is envisioned, considering the high share of converter-interfaced generation, larger load disturbances, phase imbalances, and associated control design, among others.
- The size of MG stability models has been recognized as a challenging issue, especially for interconnected MG systems with hundreds of nodes requiring the need of high modeling details. Therefore, proper modeling scale-up approaches are needed such as co-simulation, equivalencing, or MOR schemes.
- The need for system equivalent models from a system interconnection perspective have been acknowledged as an important issue. Approaches based on model reduction techniques are noted to be dependent on the types of studies to be performed, available information, and computational burden. In this context, white-box, gray-box, and black-box models are the most common modeling approaches that have been proposed.
- Several challenges specific to the design of protection systems that may impact the security analysis and stability of MGs have been identified. Appropriate tools and

extension of commercially available solutions have been identified as needed in this area.

The following sections develop in more detail the observed trends and the proposed dynamic modeling approaches for proper MG stability analysis.

III. GENERATOR AND GRID MODELING

In this section, the modeling of the MG's underlying grid is first presented, based on a three-phase power flow representation of the system. Then, relevant dynamic and static models of Synchronous Generators (SGs) and their voltage controllers, governors, and limiters are described. Finally, the dynamic models of various DERs' primer movers are briefly reviewed.

A. MG Power Flow Modeling

There are several differences in MG power flow modeling compared to traditional BPS. Unlike BPS, MGs usually operate at low/medium voltage levels in radial network topologies, as their grid backbone is basically structured as a distribution system. Thus, MGs typically have unbalanced loads and hence three-phase power flow models are necessary to analyze these systems. Moreover, conventional power flow modeling assumptions for some buses may not be valid for MGs, as IBRs at such buses may operate in different control modes, such as Grid-Following (GFL) mode or Grid-Forming (GFM) mode. Thus, while a GFL IBR can be treated as a PV or PQ bus, for a GFM IBR, droop control should be considered [41]–[43].

In [44], a three-phase power flow algorithm for islanded MGs is proposed. The proposed method considers the three main operation modes of DER units, i.e., PV, PQ, and droop modes. For a droop bus, besides the active and reactive power balance equations, relations determined by the droop control are modeled with 12 equations for each droop bus. To achieve a robust solution and global convergence, the authors implemented a Newton-trust region approach for the power flow problem. Similarly, [45] and [46] consider droop control and treat the system frequency as a state variable. In [47], a generalized MG power flow is proposed to incorporate hierarchical control schemes into MG power flows. The proposed approach is based on the direct backward/forward sweep algorithm and no slack bus is assumed, with the power loss being shared among all DERs. In [48], besides the traditional PV and PQ buses, a new bus type referred to as DER bus is introduced for DERs equipped with droop and/or secondary control. A modified Jacobian matrix is then derived to incorporate droop control and various secondary control modes, and since the Newton-type power flows are sensitive to starting points, power flows are first run with droop controls only.

Generally, three-phase representation of MGs can be performed using either sequence or phase components [49], [50]. The models to represent MG branches (π -model), three-phase loads, and three-phase transformers (Y and Δ connections) are basically the same as those used in a BPS [51]; however, for underground cables, shunt admittances must be considered. The buses for three-phase load flow can be represented as Norton equivalents, and zero and negative-sequence quantities must be appropriately incorporated. Thus, specific models can

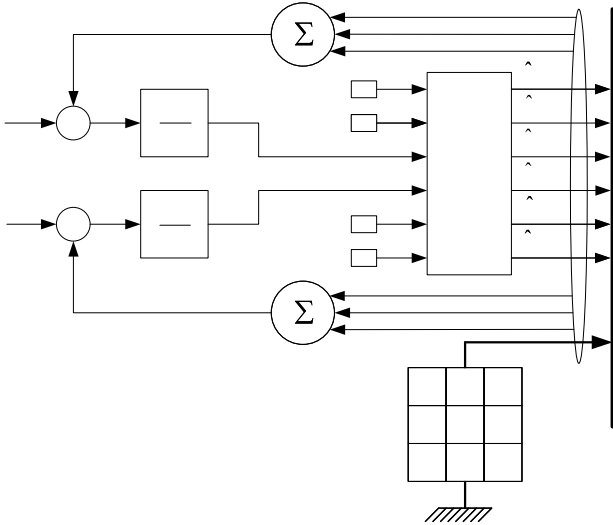

Fig. 2 Three-phase PQ bus.

be applied for PQ, PV, and Vθ (Slack) bus representation. Fig. 2 shows a schematic representation of a PQ bus, where P_{esp} and Q_{esp} are the specified active power and reactive power setpoints, respectively, and P_{inj} is calculated using the injected currents in phase components, the phase voltages at the terminal bus, and the active power through the Norton admittance matrix. Thus, P_{inj} is compared to P_{esp} and the error is “integrated” by K_p/s , which yields the imaginary part of the positive-sequence current. The treatment of the reactive powers is analogous. A detailed representation of limits is provided in [52], [53].

B. MG RMS Dynamic Modeling

For MG RMS dynamic simulations, branches, transformers, loads (except IM), reactor and capacitor banks, and switches are modeled as described in the in previous section. The components that must be changed for dynamic studies are the SG, the IM, and DERs, which may be connected with or without power electronic interfaces.

The general scheme of DER models is shown in Fig. 3, where based on different DER technologies, the interface grid can be classified into two categories:

- Direct grid-connected DER without converters.
- Indirect grid-connected DER through converters.

This section focuses on SGs and various DER prime movers, with the modeling of the power electronic interfaces being discussed in Section IV.

1) Synchronous Machine

Dynamic models of three-phase synchronous machines and IMs for stability studies presented, for example, in [54]–[56], have gained new impetus with the increased penetration of DGs connected at distribution networks and forming MGs [57]–[59], where imbalances are not negligible. Focusing on stability issues, [60] shows how to account for the negative-sequence braking torque in the three-phase SG based on a Park model. Moreover, there are no significant differences in primary/secondary controls for SGs in MGs compared to BPS.

2) Exciter, Voltage Regulator

MGs typically include significant levels of variable renewable energy and are characterized by faster dynamics than conventional grid-connected distribution systems, mainly due to

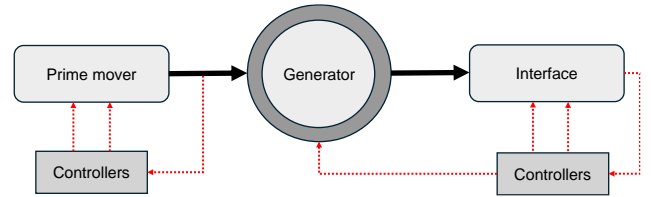

Fig. 3 General scheme of DG models.

the lack of inertia of inverter-interfaced DERs. As a result, SG may operate close to their limits and their excitation systems should be modeled with enough detail to evaluate the possible impact of excitation control limits.

The automatic voltage regulator dynamic model may be based on the IEEE Standard 421.5 [61]. However, the specification of the voltage transducer has considerable relevance in unbalanced networks. Thus, references [62]–[64] mention that the limiters of synchronous machines may not operate properly under unbalanced load conditions, with the main cause being the terminal voltage transducer. To overcome this difficulty in operation under unbalanced load conditions, a low-pass filter can be inserted in the loop for the measured field current signal. When a MG is more heavily loaded, this approach can become unstable as unbalancing increases [58]. There are several methods such as active or reactive power compensators to mitigate the resulting oscillations; for example, in [58], unbalanced voltage stabilizer are used to mitigate these oscillations.

3) Dynamic Models of DER Prime Movers

The machine of a DER based on diesel generators and a microturbines (small gas turbines) is commonly modeled using standard synchronous machine models with a six order state-space model, accounting for the stator, field, and damper winding dynamics [65]. Additionally, numerous dynamic simulations of diesel generators have used simplified diesel genset models, often containing only one or two first order transfer functions to simulate the full diesel generator system [66], [67]. In [68] and [69], a suitable model of an emergency diesel generator is presented.

IV. CONVERTER MODELING

The converter models presented in this section consider the need for modeling accuracy for stability studies highlighted in [2] and [3], as mentioned in Section I. The differences between switching and average models of converters are discussed in some detail in Section 4 of [2], where it is highlighted that switching is often neglected for control system design through simplified models obtained from averaging techniques. As highlighted in [2] and [3], converter control loops must be properly modeled to accurately represent GFL and GFM inverters in the context of MG dynamic studies, as accurate representation of dynamic conditions can only be obtained with appropriate models of the converter control dynamics. Therefore, such approximate converter models are only considered in this paper for interconnection studies in Sections VII to IX, where the required computational efficiency is partially accomplished through relevant modeling approximations.

The dominance of ac grids along with the fact that many loads at the consumer level (consumer electronics, for example) are designed to operate on an ac grid, has naturally led to the

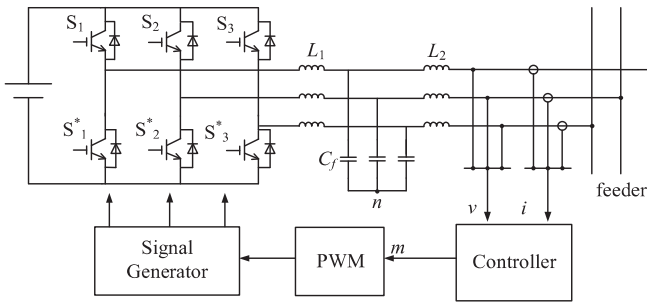

Fig. 4 A two-level, three-phase voltage-sourced inverter [79].

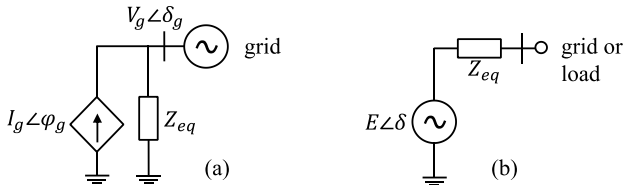

Fig. 5 Concepts of inverter controls: (a) GFL and (b) GFM.

dominance of ac MGs. However, many DERs share a key characteristic of producing electricity in dc form (e.g., solar panels, batteries, fuel cells). Therefore, the power conversion between dc and ac in MGs in the form of inverters is required [33]. Power converters, which are the main components of IBRs, are widely used in MGs for generators, storage, and loads. Research in power converter modeling and control has been prolific, with a focus ranging from modulation techniques to primary control of MGs with multiple converters [25].

From the perspective of physical realization, Voltage Source Inverters (VSIs), sometimes called Voltage Source Converters (VSCs), are the most popular (e.g., [25], [70]–[74]). These converters are usually connected to the MG through a coupling inductor, transformer, and/or LC filter, the last of which effectively creates an LCL filter together with the transformer (see Fig. 4). This coupling/filtering stage is instrumental to both filter the waveforms of both voltages and currents displayed by the inverter, and measure the grid-side quantities, thus correctly implementing the control. VSIs are traditionally controlled either in current control mode or voltage control mode, and internal control loops include modulation (e.g., space vector modulation or sinusoidal PWM), current control and voltage control in the form of PI control [75], proportional-resonant control [76], and VSG control [71], among others. It should be noted that PI and proportional-resonant controllers are specifically designed to control a specific device (e.g., capacitor voltage, inductor current); in contrast, VSG control represents a control approach that encompasses the entire converter system.

A common converter topology is the two-level, three-phase, three-leg VSI, as shown in Fig. 4. Note that there is a prevalence of three-level converters in the market due to their superior cost-performance when compared to two-level alternatives [77]. From the modeling perspective, the VSI is usually modeled as an ideal controlled voltage source [75], [78], neglecting the switching phenomena of the converters. Inner control loops are modeled in general, although some exceptions are seen in the literature, where the converter and internal control loops are simplified into an ideal voltage source or an ideal current source behind an impedance [79]. Additional outer control loops are found along with converter models, including those that enable a standalone operation, usually known as GFM controls (Fig.

5(b)), and those that enable operation in parallel with a strong grid or infinite busbar, usually known as GFL controls (Fig. 5(a)).

A. Inverter Controls

GFL control makes VSIs behave like a current source operating at constant power on steady-state and as constant current during transients [79]. Generally, GFL inverters do not control the voltage and frequency of MGs; however, GFL inverters employing reverse droop control enable GFL converters to actively participate to the regulation of voltage/frequency within MGs [80]. GFL obtain the voltage and frequency references from an external voltage measurement. Advanced Phase-Locked Loops (PLLs), which perform better under unbalanced conditions and/or phase jumps, are used in MG modeling. An overview of various types of PLLs is provided in [81]–[83]. Accurate models of the dynamics of these control loops are required for proper dynamic simulations and studies [3].

The GFM approach controls the voltage and frequency of the inverter [84], [85], making the voltage-sourced inverter behave approximately like a voltage source [86]. Because the voltage and frequency approximately remain constant, the GFM inverters can work in the standalone mode and track the loads [85]. However, GFM converters can also be implemented in converters with droop control or VSG control [87]. GFM control is considered as an emerging technology for improving the stability of highly-inverter-penetrated power systems [73], [85]. However, there are still many important research topics for GFM inverters that need to be further studied, such as: dynamics of the dc bus voltage, over-currents of inverters during faults, and interaction between different inverters and SGs [79], [88].

Imbalances can propagate through the control loops of both GFM and GFL converters, negatively impacting the performance of such converters. For example, in GFL inverters, voltage imbalance may propagate through PLLs and reach inner control loops, where PI regulators would not see dc values at steady-state [76].

Although not as prolific as with their three-phase counterparts, single-phase inverters are covered in the existing literature (e.g., [89], [90]). Single-phase inverters present greater challenges in their modeling and control, primarily due to inherent 2nd-order power ripples. This makes the PLL and power calculations more complex, with existing techniques exhibiting more pronounced nonlinear characteristics compared to three-phase inverters.

In practical manufacturers' implementations, proprietary controls are, in general, not freely available to the public. This fact has motivated a Western Electricity Coordinating Council (WECC) Task Force to produce generic solar and wind (type IV) positive-sequence RMS models [91]. To account for studies in unbalanced MGs or feeders, these models have been extended to a three-phase model [60], considering a generalized Norton equivalent.

As an alternative to the traditional state-space models used in converters, an impedance-based model (also called admittance-based or terminal-behavioral model) uses a transfer function representation for small-signal analysis [92]–[94]. This technique has been explored before by the power electronics community in dc systems (e.g. [95]), and it has been extended to ac systems, with applications in multilevel converters [96],

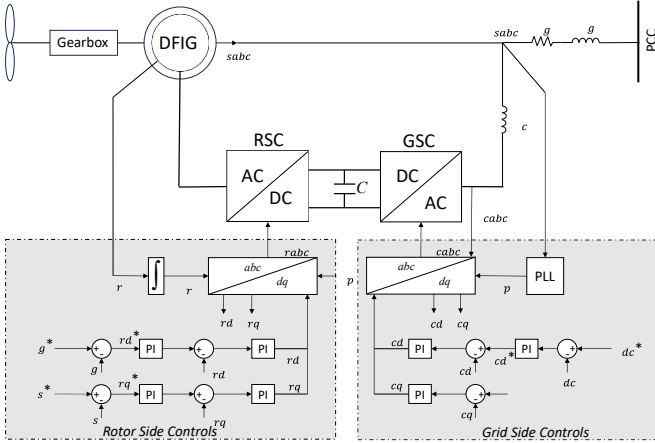

Fig. 6 Modeling of control loops in DFIG wind generator (adapted from [101]).

droop-controlled inverters [97], and full ac MGs [93], [98], [99].

B. Applications to Generation & Energy Storage

Wind generation [100]–[109], photovoltaic plants [110]–[113], ESSs [114]–[118], and fuel cells [119]–[125] are interfaced with the grid using various converter topologies. For these systems, the aforementioned converter control options are integrated together with the specific energy conversion technology. Each interface is discussed in some detail in [1], using generic models for MG stability analysis.

Wind generation is interfaced with the grid through different technologies [100], depending on the generator type. Thus, Type 1 are based on fixed-speed wind-turbines with a direct-grid-connected induction generator. Type 2 contain variable-speed wind turbines based on induction generators with a variable rotor resistance directly connected to the grid. Type 3 have variable-speed wind turbines with a direct-grid-connected Doubly-Fed Induction Generator (DFIG) and an ac/dc/ac rotor converter. Finally, Type 4 are based on variable-speed wind turbines with an induction generator interfaced through a full-scale ac/dc/ac converter. Among these topologies, Type 3 and Type 4 topologies are the most popular, as they allow operation over a wide range of wind speed variations.

Type 3 wind turbine consists of a Rotor-Side Converter (RSC) and a Grid-Side Converter (GSC), as depicted in Fig. 6, where the associated controls are shown. The control loops for both GSC and RSC are based on a cascaded PI structure. On the other hand, Type 4 wind turbines utilize back-to-back ac-dc and dc-ac VSCs. The converter on the grid side rectifies the variable frequency power generated by the rotating machine (synchronous/permanent magnet/induction machine) and the line-side converter injects the power generated into the grid.

The I-V curve of the PV cells of a solar generator depends on the irradiance and temperature. Hence, the power output of a PV array depends on irradiance, temperature, and terminal voltage, among others. To achieve the maximum power output, a controller tracks and tunes the terminal voltage, using Maximum Power Point Tracking (MPPT) approaches [111]. A typical PV system can be represented as a single dc-ac converter; however, dual-stage implementations are also found, where the

PV panels are either boosted to a higher voltage using a dc-dc converter [112], or reduced through a buck converter [110].

ESSs can be treated as dispatchable power supplies in MGs and are thus typically modeled using the previously described GFL/GFM models. Based on the type of analysis being performed, different models can be used to represent ESSs, varying in the level of detail. Hence, generalized average models are often used for system level voltage and frequency stability studies [114], [115]. These models assume a constant dc link voltage for the ESS. However, to model the ESS in EMT studies, more detailed models are required [116]. This is especially true in the case of unbalanced conditions. The level of detail may include the dc link dynamics, the dc-dc converter and the associated control structure, and an equivalent-circuit representation of the energy storage dynamics.

Fuel Cells (FCs) are modular systems with characteristics that make them suitable as DERs or as backup sources in applications such as data centers [119]. Dynamic models have been developed for different types of FCs (e.g., [120], [121]). Typically, an FC consists of a reformer, a stack, and a power conditioner. The complexity and very nonlinear behavior of the FC electrical, chemical, and thermodynamic processes result in complex models with parameters that are difficult to estimate. For FCs connected to fully controlled inverters and large capacitors or other forms of energy storage, the voltage or reactive power is assumed to be controlled through the inverter interface.

V. MICROGRID LOAD MODELING

A. Overview

This section discusses load modeling issues in MGs, covering both traditional and other types of loads found nowadays in MGs. Loads play a critical role in the stability and dynamics of the MG, as they could affect the transient, frequency and voltage stability of the MG [14]. MG stability issues associated with constant power and induction machine loads have been investigated in, for example, [126]–[128], with their impact on MG dynamics and stability being well understood. In these studies, accurate representation of MG loads is shown to be of paramount importance for the proper characterization and analysis of MG dynamics and stability.

A range of different types of loads are connected to MGs, and their composition in MGs depends on the application area [129]. New load types are also being connected to MG to enhanced demand flexibility and energy efficiency, such as flexible smart-loads [130]. These loads are mainly composed of a PEC interface at the front-end that has the capability to respond

TABLE I
LOAD TYPES IN DIFFERENT MG APPLICATIONS

Load Types	MG Application Area			
	Residential distribution feeders, and remote area MGs	Commercial Building & Institutional MGs	Industrial MGs	Transportation MGs
Resistive loads	√	–	√	√
Lighting loads	√	√	√	√
Thermostatically controlled loads	√	√	–	√
SMPS	–	√	–	–
Direct-online start motors (1-Φ)	√	√	–	√
Direct-online start motors (3-Φ)	–	√	√	√
VFD motor loads	–	√	√	√

to external signals [130], and hence their dynamics are different from conventional load types. Furthermore, it is common practice to aggregate similar load types and represent them as aggregated loads in stability and dynamic studies [131]. Therefore, there are depth and breadth aspects to consider when representing loads in MG dynamic and stability studies.

MG applications include residential distribution feeders, commercial buildings, industrial facilities, institutions (e.g., research centers and universities), and transportation systems (e.g., ships). Therefore, the composition of each load type depends on the MG application area. For example, in commercial building MGs, lighting loads, Switch-Mode Power Supplies (SMPS), and motor loads are dominant [132]. Table I lists the dominant loads for different MG applications. However, it should be noted that several common household electronic devices nowadays using ac/dc adapters/chargers, such as personal computers, smartphones, routers, smart TVs, EV chargers, and even LED lights, can be considered as SMPS loads. In addition, home appliances such as existing variable speed air conditioners and refrigerators use VFD motors. Given the energy needs of these appliances, SMPS and VFD motor loads are becoming increasingly prevalent in residential MGs.

In addition to the load types listed in Table I, the following load types are also emerging in MGs:

- *Smart loads* are flexible loads that can vary their power consumption based on an external signal [130]. Usually, these loads have a power electronic interface, and they are used for providing demand response and other services to MGs.
- Many commercial building MG installations are now being built with plug-in EV bays and thus these are becoming an important load segment in modern building MGs. Therefore, EVs should be modeled with special emphasis on the charging dynamics associated with the charger [133].

B. Models for Dynamic and Stability Studies

The load models available for dynamic and stability studies can be fundamentally categorized into four types [134], [135]: (1) Static load models in which the active and reactive power of

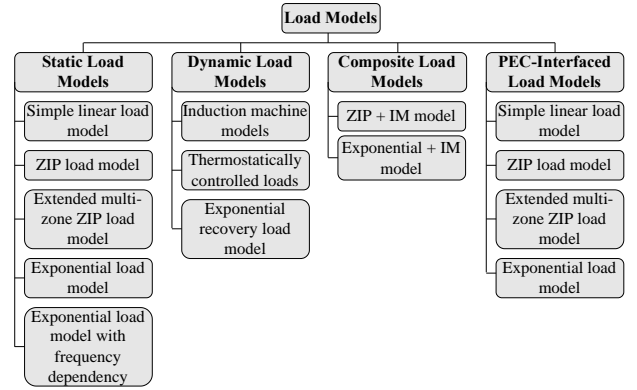

Fig. 7 Classification of load models.

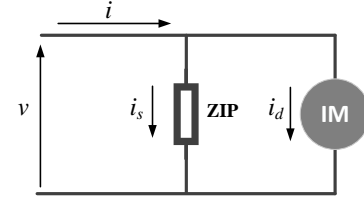

Fig. 8 ZIP+IM composite load model.

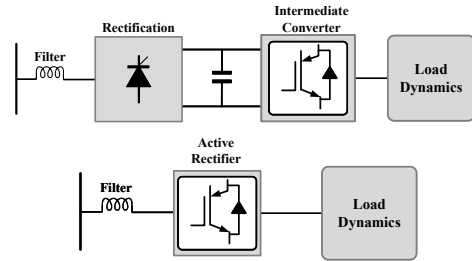

Fig. 9 General structure of a PEC-interfaced load.

the load are determined by the terminal voltage and frequency characteristics; (2) dynamic load models in which the load active and reactive power vary with time in addition to voltage and frequency variations at their terminals; (3) composite load models in which static load models and reduced-order dynamic induction machine loads are combined; and (4) PEC-interfaced load models that have a front-end PEC interface showing constant power behavior within a specified voltage and frequency range, with dynamic nonlinear characteristics outside that range. The general classification of the load models is shown in Fig. 7.

Static load models are the most commonly used models in MG dynamic studies [135]. These models can be mainly divided into five types: (1) Simple impedance load model; (2) ZIP load model; (3) extended multi-zone ZIP load model; (4) exponential voltage load model; and (5) exponential load model with both voltage and frequency dependency/sensitivity.

Dynamic load models can be mainly divided into three types: (1) Direct On-line (DOL) start induction machine models; (2) thermostatically controlled models; and (3) exponential recovery models. Among the dynamic load models, the DOL start IMs (both three-phase and single-phase) are the most significant load types found in MGs, due to their sensitivity to terminal voltage and frequency. It has been determined that IM characteristics have a significant impact on the dynamics and stability of MGs [136]. Since Variable Frequency Drives (VFDs) have a power electronic interface, they have been categorized under PEC-interfaced loads in Fig. 7. Thermostatically

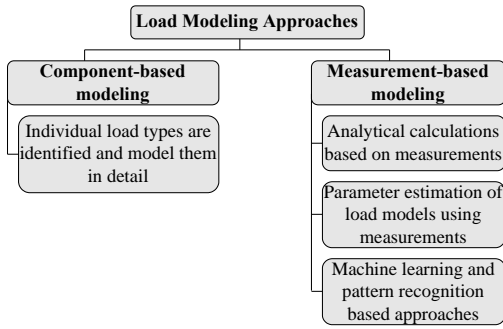

Fig. 10 Classification of load modeling approaches.

controlled loads (e.g., air conditioners and heaters) are also considered dynamic loads, due to their time-dependent response.

Composite load models represent both static and dynamic loads as a lumped model. Common composite load models are composed of a ZIP load in parallel with a simplified IM load, as shown in Fig. 8 [137].

Different types of PEC-interfaced loads are connected to MGs and include SMPS, light-emitting-diode loads, VFDs, smart loads, and EVs. A generic structure of a PEC-interfaced load is shown in Fig. 9, where a passive filter is connected at the front-end of the PEC-interfaced load to eliminate harmonics, which can be either a simple inductive (L) filter or an LC or LCL type filter. The ac voltage is converted to dc using a simple rectifier, a controlled rectifier, or an active rectifier.

C. Loads Representation in Stability and Dynamic Studies

The load modeling approaches used for representing loads in stability and dynamic MG studies can be broadly classified into two categories: (1) Component-based and (2) measurement-based modeling [137], as illustrated in Fig. 10. In component-based load modeling, each load type in the MG is identified and then modeled in detail. In measurement-based load modeling, measurements are obtained via data recorders (e.g., event recorders) and then various techniques are applied to derive the load model.

Measurement-based load modeling techniques can be classified into three types: (1) Analytical-calculations-based on measurements, (2) parameter estimation of load models using measurements, and (3) machine learning and pattern recognition-based approaches [128], [132]. Analytical-calculation-based approaches are rarely used in the MG context since specific tests should be conducted to capture the necessary measurements from the load to calculate the load model parameters (e.g., induction machine parameter estimation).

The selection of the appropriate load modeling approach depends on the following factors: (1) nature of the dynamic stability investigation (e.g., voltage stability, frequency stability); (2) number of loads in the MG and size of the MG; (3) relative size of each load (e.g., if the size of a particular load is significant, then it must be represented in detail), and (4) availability of data for modeling.

VI. IMPACT OF COORDINATED CONTROL AND COMMUNICATIONS ON MICROGRID STABILITY

One of the most challenging aspects in the control of MGs is that heterogeneous resources within the MG must be coordinated to achieve the desired performance objectives. Such

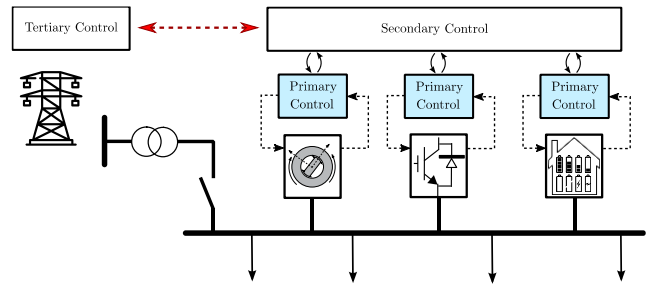

Fig. 11 Illustration of traditional hierarchical MG control.

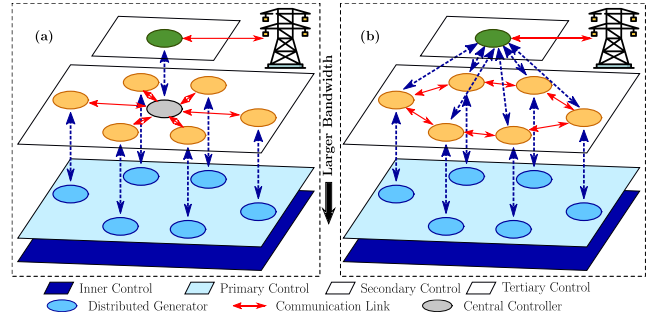

Fig. 12 Architectures for secondary control: (a) centralized and (b) distributed.

coordinated control can be achieved via the implementation of an appropriately designed digital control system, with measurements and commands being transmitted throughout the MG via some available communication infrastructure. These control and communication systems are the main subject of this section, with a focus on when and how they impact the overall MG dynamic stability.

The conventional three-layer hierarchical control architecture of MGs is depicted in Fig. 11, which shows the decomposition into distinct primary, secondary, and tertiary control layers [138]. This three-level hierarchical architecture has largely been inherited from the control of BPS and attempts to strike a balance between the respective weaknesses and advantages of decentralized and centralized control. Each layer in the control hierarchy has a specific role, spatial scale, and timescale; we describe each layer next. Other overviews of MG architectures and controls can be found in [129], [138]–[147].

Tertiary control refers to the coordination between the MG and an external entity, such as the host grid, a market operator, or even to a collection of other MGs in a multi-MG configuration [129], [142]. The role of the primary control layer is to continuously stabilize the frequency and voltage of the MG in the presence of unmeasured load and generation disturbances, to which controls respond quickly, with time constants in the order of seconds or less. The secondary control layer is the global control layer within the MG, which is responsible for all functionality that requires coordination between MG components. The most common objective of the secondary control layer is that of ensuring restoration of frequency and voltage to their nominal values. Various other objectives are sometimes also seen as being responsibilities of the secondary control layer, including improvement of power quality, balancing of load across phases, shedding of noncritical loads, coordination of black start, and security monitoring [138], [140]. In this document, the architecture of a secondary control system refers to the spatial organization of where measurements are taken, and

TABLE II
COMMUNICATION TECHNOLOGIES APPLICABLE TO MGS

Type	Technology	Cost	Complexity of expansion	Distance coverage	Latency	Control level		
						P	S	T
Wired	Optical fiber	xxx	xxx	xxx	x	✓	✓	
	Twisted pairs	xx	xxx	x	x	✓	✓	
	Power line	x	xxx	x	xx			✓
Wireless	Wi-Fi	x	x	x	x		✓	✓
	ZigBee	x	x	x	xx			✓
	Bluetooth	xx	x	x	xx			✓
	Cellular 3G	xxx	x	xx	xx			✓
	Cellular 4G	xxx	x	xx	xx			✓
	Cellular 5G	xxx	x	xx	x			✓
	LoRa	xx	x	xx	x			✓

how they are processed to determine secondary control actions. The possible architectures are classified as centralized and distributed, as depicted in Fig. 12.

Depending on the control problem and control timescale under consideration, it may be the case that little dynamic interaction occurs between system-level coordinating MG controllers and the lower level dynamics of the MG. An example of this would occur when a MG operates in grid-connected mode, where the frequency and voltage of the MG are largely imposed by the interconnection to the host grid. In such a scenario, the use of resources within the MG is typically managed via an Energy Management System (EMS), which optimizes the set-points of devices based on market prices and on forecasts of generation and load [148]. Such a high-level control scheme can be designed confidently without consideration of the MG dynamics.

A more complex scenario can occur in the case of an isolated or islanded MG, which is disconnected from the main grid. In this case, DERs must be quickly and reliably coordinated to maintain the MG frequency and voltage near nominal levels, leading to the potential of dynamic interaction between system-level MG controllers and the underlying MG dynamics. The dynamic performance of such a coordinated control system depends on several factors, including (1) the chosen control architecture, (2) the dynamic controller design and tuning, (3) the manner in which the controller is digitally implemented, and (4) the capabilities and performance of the communication infrastructure.

Both wired and wireless communication technologies can be deployed for use in MGS. Typically, the signals within an individual device in the MG (e.g., a converter-based DER), such as measurements and control signals, are carried via wired connection like optical fiber or Unshielded/Shielded copper Twisted Pairs (UTP/STP). On the other hand, information communicated between different devices within the MG (e.g., between different DERs, or between a DER and the MG central controller) travels through wired or wireless technologies depending on the specific characteristics of the system. Characteristics that influence the choice of wireless versus wired communication include distance, implementation and maintenance costs, and security. The main advantages/disadvantages of wired and wireless communications are summarized in Table II, based on [149].

The key messages are that several key digital control and communication system effects should be considered when

TABLE III
MODELING CATEGORIES

Modeling category	Different representations
Power electronic conversion	Detailed vs. averaged switching
ac waveforms	Instantaneous (waveform) vs. envelope
ac lines	Three individual phases vs. single-phase equivalent

testing proposed secondary control implementations, particularly the effects of controller sampling rates and communication delays. Distributed control implementations can have significant benefits over centralized implementations, as they remove a single point of failure from the MG and rely more on localized measurements for control purposes. The development of distributed and multi-agent secondary control techniques for MGS has been increasing [150]–[153], but further work is required to understand whether distributed solutions are feasible and appropriate for secondary control objectives beyond frequency and voltage regulation.

VII. MODELING TOOLS

A variety of diverse modeling tools is available for simulating MGS. Thus, it is useful to categorize the used techniques according to the approaches to model network elements and representing waveforms, as illustrated in Table III. The left column lists the categories, while the right column gives the different modeling approaches. For the modeling of power electronic converters, one can distinguish between detailed and averaged representations of switching processes. AC waveforms may be simulated according to their instantaneous waveshapes or just as envelopes, and ac lines may be represented individually for each of the three phases, while a single-phase equivalent can be an alternative. The first two categories are elaborated upon immediately hereafter, while the third category is discussed in the context of unbalances in Sections VIII.A and VIII.B.

A. Modeling of Detailed vs. Averaged Switching of Power Electronic Converters

Power electronic converters often pose challenges to the modeling and simulation of the systems in which they are embedded. This is due to the fact that power electronic converters operate based upon high-frequency switching, which requires the use of small simulation time-steps for the numerical integration of system equations.

To address the computational burden of simulating power electronic systems, several solution techniques have been developed. Detailed Equivalent Models (DEMs) use specialized techniques such as Thevenin-based equivalents to create numerical models that retain accuracy while reducing computational complexity. These methods are widely used for simulating converters of various forms, increasing computational efficiency by reducing the number of switching nodes that the converter model adds to the circuit model [154], [155].

Another category of models for reducing the computational burden of converter simulations are Average-Value Models (AVMs) [156], [157]. AVMs are based on the observation that the response of a well-designed power electronic converter is primarily dominated by frequency ranges well below the switching frequency, with negligible harmonic content that can

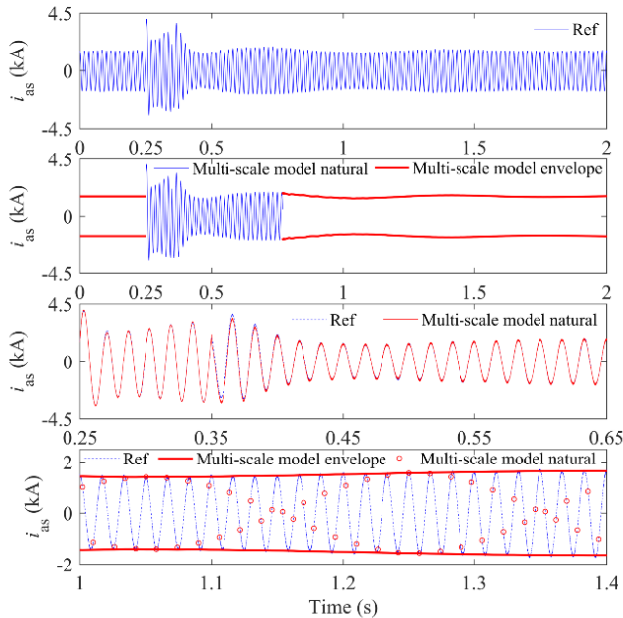

Fig. 13 Phase-a stator current i_{as} of DFIG; (a) natural waveform of the reference solution in PSCAD; (b) natural and envelope waveforms in the multi-scale simulation; solid light: natural waveform; solid bold: envelope; (c) zoomed-in view of i_{as} during electromagnetic transients, dashed: natural waveform of the reference solution in PSCAD/EMTDC; solid: natural waveforms in the multi-scale simulation; (d) zoomed-in view of i_{as} during electromechanical transients, solid light: natural waveform of the reference solution; solid bold: envelope waveforms in the multi-scale simulation; circle: natural waveforms in the multi-scale simulation.

be ignored without much practical implication. Thus, AVMs capture those frequency ranges relevant to intended dynamic converter functions, while ignoring the high-frequency switching transients, thus allowing the use of much larger simulation time-steps, as this is computationally advantageous. While DEMs and AVMs are applicable in numerical simulation tools, most AVMs support the formulation of explicit dynamic equations or equivalent circuits that can be readily linearized and used in conjunction with established control system and stability analysis methods.

The concept of averaging a quantity can be extended to what is known as generalized multi-frequency averaging that also includes higher-order Fourier components of ac or dc quantities. In the context of converters with ac variables, such as inverters, the averaging process yields a time-varying complex number that describes the amplitude and phase angle of the respective harmonics, usually referred to as dynamic phasor. This is a powerful technique, as it allows applying the concept of averaging to dynamic phasor analysis methods common in power systems.

B. Modeling of Natural vs. Envelope Waveforms

While some studies call for an accurate tracking of ac waveform details, for other studies envelopes are sufficient. EMT simulators support the accurate natural waveform tracking at small time-step sizes. Larger time-steps are possible when just tracking the envelopes in ac power systems thanks to dynamic phasor techniques [158]–[161]. The less accurate quasi-static phasor calculus is obtained as a simplified version when the transient behavior due to the network inductances and capacitances is neglected.

In practical simulation tools, the time-step size is treated as a simulation parameter. The introduction of the shift frequency as an additional adaptive simulation parameter allows for multi-scale simulation. For a frequency-shift of zero, EMT modeling is emulated, while an actual shifting of the Fourier spectra enables dynamic phasor calculus. This method is also referred to as Frequency-Adaptive Simulation of Transients (FAST) [160], [162]. A case study of multi-scale modeling of a DFIG wind energy conversion system and comparison with an EMT solution based on PSCAD is illustrated in Fig. 13, as detailed in [163]. The stator current of the DFIG in phase a is shown, and it can be observed that there are no visible differences between the multi-scale simulation and the corresponding PSCAD simulation. Whenever the envelopes are shown, the shift frequency is set to f_s Hz.

Co-simulation combines two or more solvers by performing a simulation of a system based on a segmentation into several subsystems and assigning distinct solvers or tools based on the properties of each subsystem, with the subsystems being coupled through interfaces [164]. For example, a multi-rate co-simulator could simulate an area of main interest through an EMT-based method, while modeling the remainder of the system using dynamic phasors with a larger time-step.

C. Main Trends

In the context of MGs, tools relying on quasi-static phasor calculus, which are typically referred to as transient stability programs or RMS models, are not suitable for accurately analyzing such systems, especially where there is a significant share of converter-interfaced generation [165]. On the other hand, simulators based on dynamic phasors combined with average-value modeling are very well suited for small-disturbance analysis as well as larger disturbances concerning load changes, fluctuation of generation, phase imbalances, and corresponding control design. EMT-type models combined with the modeling of power electronic switches can be used for large-disturbance analysis concerned with significant faults such as short-circuit fault transients and harmonics. EMT tools may also be used for small-disturbance analysis; however, compared with envelope tracking in dynamic phasor calculus, a much smaller time-step size is required in that case.

The FAST multi-scale modeling approach integrates the virtues of dynamic phasor calculus and EMT-based techniques within one unified framework. This approach is of particular interest when broad time scales are considered, for example, when a fault and small disturbances are considered within one study. Finally, co-simulation may be applied when the techniques of dynamic phasors, EMT-based, or multi-scale modeling are to be allocated to different subsystems. Possible applications are the study of multi-MG systems or MGs coupled with large-scale power systems.

VIII. MODELING SCALE-UP

MG stability models can become very large for three main reasons:

1. Large MGs containing hundreds of nodes.
2. MGs may be interconnected with other MGs, also known as networked MGs, to leverage their resources.

TABLE IV
EXAMPLES OF LARGE-SCALE EXAMPLE SYSTEMS MODELED BY USING SCALE
UP MODELING APPROACHES

Test system	Number of nodes/generators	Simulation approach
IEEE 8500-node distribution system	8500/1	Unbalanced transient stability with single phase motor loads [166]. Electromagnetic transients with power flow initialization [167]
MG based on prototypical distribution feeder, R3-12.47-3	5,252/13 (3 synchronous machines and 10 inverters) [79]	Unbalanced RMS model (transient stability), 5,252 node MG model with 3 diesel generation and 10 inverter models (GFM and GFL) [79]
IEEE 342-node low voltage network test system	342/various primary feeders [168]	Dynamic phasors
IEEE 123-node test system	123/4 [59]; 123/7 (partitioned into 3) [169] [170]; 123/4 (with 500 motor loads) [171]	Unbalanced transient stability
IEEE 34-node test system	34/7 [172]	34 node MG in RMS (transient stability) and electromagnetic simulations [172]
IEEE 13-node test system	13/2 [59]	Unbalanced transient stability
IEEE-39-bus transmission system model with 6 MG models	39/16 [173]	Balanced transient stability at transmission level with multiple grid-connected MGs

3. High modeling detail sometimes needed to model some loads, such as in the case of loads containing many motor loads.

Many simplifications normally used to deal with these system-scale issues do not typically apply to MGs. For example, capturing unbalanced loads and lines is critical for MG modeling; therefore, RMS models traditionally used in transmission are generally not enough for analyzing a large-scale MG. The following ways of dealing with the scaling problem can be considered:

- Use of modeling assumptions like those used in RMS models (also known as electromechanical or transient stability modeling or quasi-static phasor calculus as mentioned in Section VII) but capturing unbalances and the fact that MGs do not generally have a strong substation or generator.
- Dynamic phasor approximation can capture additional dynamics including effects such as inrush currents, while maintaining lower computational cost than EMT models with microsecond time-steps.
- Adaptive simulation or FAST that switches between steady-state and dynamics when needed.
- Co-simulation where different models are interfaced for information exchange at each simulation time step for two or more models.
- Equivalencing or MOR.

The first four approaches in the bullet list above are discussed in this section, while the last item, i.e., equivalencing, is covered in Section IX. Table IV illustrates examples of test systems and associated simulation approaches.

A. Unbalanced RMS Models

Traditional RMS models have been applied at the transmission system level, which is mostly balanced, allowing the representation of the network using the positive sequence only. In the case of MGs, it is important to capture full imbalances, considering the fact that typically there is no strong substation voltage source, especially for islanded MGs. RMS MG models that capture full imbalances with an initialization equilibrium for synchronous machines have been developed [59].

Large MG systems have been tested in RMS models, taking advantage of the scalability of the approach in terms of computational efficiency. Large test feeders have been tested configured as MGs [79], [169]–[171], and utility MGs have also been tested with these models to study distribution resilience, such as in [174]. Computational efficiency for this approach associated with the ability of using larger time steps has been reported to be of a speed 7x or greater with respect to EMT-based models [59]; however, it is important to highlight that, even though unbalanced conditions are captured, accuracy is reduced due to the simplifications of the RMS models vis-à-vis the use of full EMT-based models.

B. Unbalanced Dynamic Phasor Models

Dynamic phasor modeling is discussed in some detail in Section VII. Large MGs systems have been tested using the dynamic phasor approach. Scalability has been tested on the IEEE 342-node low voltage network test system [168], which represents an urban core system with meshed topology fed from various sources that are feeders in normal conditions but could be thought of as emergency generation in a MG configuration. The phasor dynamic approach has also been applied to the modeling of single-phase IM loads as part of a multi-state load model in [171], where a MG is constructed from the IEEE 123-node system with 500 motors.

C. Adaptive Simulation and Co-Simulation

As the MG stability models increase in size and complexity, two popular methods to keep the simulations tractable are to utilize adaptive simulation capabilities and to leverage co-simulation platforms. For adaptive simulation scenarios, two primary approaches have emerged. The first is to select between different model types or representations of the system, as necessary [166], such as utilizing traditional multi-state ZIP models and power flow for periods of no change in the system. However, when an event occurs, the simulator changes to differential-equation-based models and smaller time-steps for more detailed analysis. Multi-scale modeling as discussed in Section VII may also be considered in this context. The second approach is to adjust the time-step of the simulation, as in the case of [175], where state-driven models are used, advancing the simulation to the next predicted state change.

Co-simulation platforms serve to coordinate multiple different simulators into a common simulation scenario. In simple words, this method breaks the simulation down into smaller portions in identical software that are solved individually, and then coordinated into a larger, aggregate MG model, effectively parallelizing the simulation. Other co-simulation approaches leverage different simulators for specific domains of analysis, and coordinate and combine the results for greater detail in the full simulation. Both approaches have since evolved into

commercial software platforms [176], as well as more generalized co-simulation platforms.

D. Control and Communications in Networked MGs

As the complexity and scale of MG analysis increases, methods to operate and optimize the economics of the resources are increasingly of interest. There are numerous articles on improved control or optimization strategies for MGs and networked MGs. Properly deploying and evaluating these techniques requires increasing levels of detail in both the control systems themselves, but also the communication network between devices. Co-simulation platforms, such as Hierarchical Engine for Large-scale Infrastructure Co-Simulation (HELICS) [177], are obvious platform choices to perform these evaluations.

E. Coordination of MGs Connected Through the Transmission System

Networked MGs could also be connected through a transmission system, further scaling up the modeling problem. This configuration could lead to thousands of MGs connected through a transmission system, in which case the problem of coordinating among these many MGs becomes relevant. An analysis of the dynamic stability impact due to the penetration of multiple MGs through a transmission system is presented in [173], where the MG aggregated model consists of a power balance between load, storage, and other distributed energy resources controlled centrally using an electricity market pricing mechanism. In the simulation example discussed in this reference, aggregated MGs models are connected through the IEEE-39-bus transmission system.

IX. EQUIVALENT MODELS OF MICROGRIDS

In the context of electrical grid studies, most loads, including some complex ones, such as buildings, small factories, etc., are usually modeled as lumped elements, representing the behind-the-meter aggregated loads. However, MGs, which are characterized by more complex components (particularly DERs) and responses due to control actions, entail more detailed modeling. This is particularly relevant in the context of Active Distribution Networks (ADNs) and BPS with embedded MGs, in which MG equivalent models allow accurate and computationally feasible simulations.

This section is intended as a survey of available techniques to produce equivalent aggregated models for MGs. The main idea is that, for dynamic simulation purposes, there is an area or component of interest in the MG that does not need to be represented in detail, highlighting the principle that there is no “general-purpose” method for producing a dynamic equivalent of a MG. This requires that at least some information about the phenomenon to be studied must be available, which is crucial for determining the most adequate equivalent model structure and parameters. Based on the level of available information, the most suitable approaches to build the desired equivalent can be divided into three categories: white-box, gray-box, and black-box approaches. The machine learning and data-driven modeling techniques discussed in this section focus on their application to the analysis of interconnection of several MGs. Data-driven techniques are useful for application to ADN (e.g., [178]) and MG equipment modeling (e.g., [179]); however,

these specific modeling approaches are beyond the scope of the current paper and are hence not discussed here in detail.

A. White-Box Equivalents

One approach consists of detailed modeling of the MG using “white-box” techniques. For a method to be classified as a white-box one, full knowledge about the system structure is required, and, in some cases, about the operating conditions as well (e.g., linear analysis techniques). This knowledge is used to build an equivalent that can reproduce the dynamic behavior of the portion of the system to which the equivalent is referred. These types of equivalents are usually reduced-order models with physical meaning, albeit this is not a strict requirement.

The selection of the model reduction technique depends on the types of studies that need to be performed. Thus, there are generally two equivalent types suited for the following studies: (1) transient stability studies and (2) small-signal or -disturbance stability studies. However, this may not be practical, as it can significantly increase the computational burden of simulations (especially for large MGs) and requires knowledge of all MG components and their parameters, which may not be available. Hence, equivalent aggregated MG models can be found proposed in the literature instead, with gray-box and black-box models being among the most common modeling approaches. In these approaches, parameters are typically obtained using system identification and measurement-based techniques or data from simulations and/or laboratory experiments [180].

B. Gray-Box Equivalents

Gray-box approaches have been used to obtain equivalent models of MGs applied to dynamic studies of distribution or BPS. In a gray-box approach, a suitable model structure based on prior knowledge or physical insight about the system is used to represent the real system with unknown parameters. The model structure is not the exact composition of the system, but it should be capable of representing its main characteristics with components that have a physical meaning or interpretation [181], [182].

Gray-box approaches are based on measurements, since they do not require detailed knowledge of the architecture and composition of the system, so measurements are used to identify the model parameters. These techniques require field measurements, which is challenging, given the difficulty in obtaining parameters from actual MG equipment and associated control systems. However, as distribution grids evolve in the context of smart grids, actual measurements are becoming more widely available, which can be used as input data to these types of approaches.

Equivalent models of MGs can be represented either by equations used to represent nonlinear state-space models of the MG components, or standard models available in various existing simulation tools. To tune the required equivalent model parameters, field measurements or sampled data taken from the simulation of the full model can be used. Therefore, as opposed to white-box approaches, gray-box techniques rely heavily on sampled information collected at specific points of the MG to build the corresponding equivalent model.

C. Black-Box Equivalents

Black-box models of MGs have been proposed for evaluating the impact and interaction of MGs with the grids to which these are connected. The main advantage of black-box models over other MG equivalent models is that these do not require knowledge of the MG topology, nor the individual components [183]. Most works on black-box modeling are based on representing the MG as active P and reactive Q power injections at the PCC [184], or as a current source which, along with the voltage at the PCC, yields P and Q injections at the PCC [185], [186]. In [184], two methods are proposed to develop a small-signal dynamic black-box model of a MG, based on actual measurements obtained in a laboratory setup. In [187], parameter identification using a Prony nonlinear least-square optimization method proposed in [184] is further explored and enhanced, introducing the concept of model correction factors. Other works based on polytopic models, such as [188]–[192], overcome some limitations of Prony-analysis and linear-state space black-box models to accurately reproduce the behavior of detailed models for a wide range of operating points. In [179] and [193], a recursive damped least square method is used as the system identification technique to develop a black-box model of a MG. Black-box models based on ANNs have also been proposed in the literature to represent equivalent MGs. For example, in [185], Recurrent NNs (RNNs) are used to represent a MG connected to a distribution network, where the MG corresponds to part of a low voltage distribution grid that includes multiple loads, three small PV units, and a single-shaft microturbine.

X. MODELING NEEDS IN MICROGRID PROTECTION

Traditional distribution system protection design is assisted by software tools that automate the necessary calculations of source impedance as seen from various points along the circuit. These tools, which are commercially available, are designed to automate the calculations associated with the most commonly used protection methods in distribution systems such as coordinated time-overcurrent. However, these tools may not always be applicable to the protection design for MGs. There are several challenges specific to the design of protection systems for MGs [194]–[197]. This section describes some of them.

A. Requirements for Protection Modeling Tools for MGs

Ideally, a protection design tool for MGs would have the following properties:

- The tool should be able to reliably initialize and provide fault current calculations for systems that do not have an infinite bus. It should also initialize and provide realistic fault current calculations for systems with multiple IBRs.
- While preserving the capability to simulate on-grid fault currents, the tool should be able to reasonably represent the dynamics of MG sources during fault events, such as the time-varying fault current from SGs, the limited current from IBRs, the variations in negative-sequence current magnitudes and phase angles between various sources, and any dc-side limitations of IBRs.
- The tool should possess some forms of multiple-run capability that would allow the tool to assist in the design of a protection system that works under all expected MG

conditions (e.g., different source combinations or different tie-line states).

- The tool should be able to simulate the expected response of a specific device under the dynamic conditions expected in the faulted MG. This includes but is not limited to the responses of current transformers, potential transformers, symmetrical component and RMS calculations, and other algorithmic elements in the presence of rapidly-varying frequency or voltage.
- The tool should evolve over time as MG protection methods are developed and come into use. For example, adaptive protection, fault location, isolation, and service restoration systems may be near-term candidates for protection of MGs with non-oversized IBR sources; thus, MG protection design tools should be developed to support the deployment of these systems.
- The tool should have all the above properties and capabilities for both ac and dc systems.

Accumulated experience and R&D efforts will lead to the development and standardization of effective MG protection techniques, with standardized protection approaches being sufficient for most MG protection designs. Commercial distribution protection modeling tools will eventually include many useful capabilities for setting the parameters of standardized MG protection in “typical” cases. In the near term, and into the future for “nontypical” cases, EMT simulations are necessary for protection design; in this context, faster, easier-to-use EMT tools are necessary. Furthermore, relay control hardware in the loop will become increasingly common for testing implementations of novel MG protection functions in relays.

XI. CONCLUSIONS

The document covered major issues associated with component models for MG stability studies and dynamic simulations, including generator and grid modeling, full and average converter models, unbalanced and balanced system conditions, dynamic and static loads, protection requirements, and detailed and simplified controls considering communications delays, packet losses, and security issues. Considering the future integration of grids and MGs to form broad integrated networks, a discussion was presented of the use of phasor vis-à-vis EMT simulation tools for MG dynamic stability studies, as well as modeling scale-up issues and MG equivalent models, specifically white-, grey-, and black-box models, were discussed. A review of state-of-the-art modeling approaches and trends has been presented for each topic.

This TF paper and companion report constitute a modeling guide for R&D groups working on current MG development and standards with a focus on stability and associated control issues that will allow them to choose appropriate modeling approaches depending on their particular interest. The work also addresses various modeling issues being faced as MGs evolve, such as cyber-physical modeling and multi-MG issues. Hence, it should be helpful for studies investigating the future of MGs, while identifying challenges in MG network, DER, control, and communication and protection systems dynamic modeling, especially in the context of the wide integration of MGs in ADNs and bulk power systems.

ACKNOWLEDGEMENT

The following colleagues who contributed to TF report [1] are gratefully acknowledged: Fabián Calero, University of Waterloo; Roberto Cárdenas, University of Chile; Ying Chen, Tsinghua University; Phylcia Cicilio, University of Alaska; E. Crisostomi, University of Pisa; Lingling Fan, University of South Florida; Mostafa Farrokhhabadi, University of Calgary; Tatiane Fernandes, Federal University of Sao Carlos; P. Ferraro, Imperial College London; Shaahin Filizadeh, University of Manitoba; Samuele Grillo, Politecnico di Milano; Harshani Konara, RTDS Technologies Inc.; Federico Milano, University of Dublin; Daniel Olivares, Universidad Adolfo Ibáñez; Vedran Peric, Technical University of Munich; Artur Piardi, Itaipu Technological Park; Mike Quashie, ARCUS Power Corp.; Ujjwol Tamrakar, Sandia National Laboratories; Zhiyuan Tang, Sichuan University; Xia Yue, China Agricultural University; and Tan Zhang, MPR Associates, Inc.

REFERENCES

- [1] IEEE PES Task Force on Microgrid Dynamic Modeling, "Trends in Microgrid Modeling for Stability Analysis - Technical Report (PES-TR106)," 2023.
- [2] IEEE PES Task Force on Microgrid Stability Analysis and Modeling, "Microgrid Stability Definitions, Analysis, and Modeling - Technical Report (PES-TR66)," 2018.
- [3] M. Farrokhhabadi et al., "Microgrid Stability Definitions, Analysis, and Examples," *IEEE Trans. Power Syst.*, vol. 35, no. 1, pp. 12–29, 2019.
- [4] "IEEE Standard for Interconnecting Distributed Resources with Electric Power Systems," IEEE Std 1547-2003, pp. 1–28, 2003.
- [5] A. Salam, A. Mohamed, and M. A. Hannan, "Technical Challenges of Microgrids," *ARPJ J. Eng. Appl. Sci.*, vol. 3, pp. 64–69, Jan. 2008.
- [6] "IEEE Standard for Interconnection and Interoperability of Distributed Energy Resources with Associated Electric Power Systems Interfaces--Amendment 1: To Provide More Flexibility for Adoption of Abnormal Operating Performance Category III." IEEE Std 1547a-2020 (Amendment to IEEE Std 1547-2018), pp. 1–16, 2020.
- [7] M. Ding, Y. Zhang, and M. Mao, "Key technologies for microgrids-a review," in *2009 International Conference on Sustainable Power Generation and Supply*, 2009, pp. 1–5.
- [8] M. Jamil, B. Hussain, M. Abu-Sara, R. J. Boltryk, and S. M. Sharkh, "Microgrid power electronic converters: State of the art and future challenges," in *2009 44th International Universities Power Engineering Conference (UPEC)*, 2009, pp. 1–5.
- [9] R. Zamora and A. K. Srivastava, "Controls for microgrids with storage: Review, challenges, and research needs," *Renew. Sustain. Energy Rev.*, vol. 14, no. 7, pp. 2009–2018, 2010.
- [10] Z. Zeng, H. Yang, and R. Zhao, "Study on small signal stability of microgrids: A review and a new approach," *Renew. Sustain. Energy Rev.*, vol. 15, no. 9, pp. 4818–4828, 2011.
- [11] X. Wang, J. M. Guerrero, F. Blaabjerg, and Z. Chen, "A Review of Power Electronics Based Microgrids," *J. Power Electron.*, vol. 12, no. 1, pp. 181–192, 2012.
- [12] S. N. Bhaskara and B. H. Chowdhury, "Microgrids — A review of modeling, control, protection, simulation and future potential," in *2012 IEEE Power and Energy Society General Meeting*, 2012, pp. 1–7.
- [13] IEEE Std 1547.4-2011, "IEEE Guide for Design, Operation, and Integration of Distributed Resource Island Systems with Electric Power Systems," 2011.
- [14] R. Majumder, "Some Aspects of Stability in Microgrids," *IEEE Trans. Power Syst.*, vol. 28, no. 3, pp. 3243–3252, 2013.
- [15] M. S. Mahmoud, S. Azher Hussain, and M. A. Abido, "Modeling and control of microgrid: An overview," *J. Franklin Inst.*, vol. 351, no. 5, pp. 2822–2859, 2014.
- [16] A. El Aroudi, D. Giaouris, H. H. Iu, and I. A. Hiskens, "A Review on Stability Analysis Methods for Switching Mode Power Converters," *IEEE J. Emerg. Sel. Top. Circuits Syst.*, vol. 5, no. 3, pp. 302–315, 2015.
- [17] M. S. Mahmoud, M. Saif Ur Rahman, and F. M. A.L.-Sunni, "Review of microgrid architectures – a system of systems perspective," *IET Renew. Power Gener.*, vol. 9, no. 8, pp. 1064–1078, Nov. 2015.
- [18] S. Wang, J. Su, X. Yang, Y. Du, Y. Tu, and H. Xu, "A review on the small signal stability of microgrid," in *2016 IEEE 8th International Power Electronics and Motion Control Conference (IPEMC-ECCE Asia)*, 2016, pp. 1793–1798.
- [19] S. K. Kaper and N. K. Choudhary, "A review of power management and stability issues in microgrid," in *2016 IEEE 1st International Conference on Power Electronics, Intelligent Control and Energy Systems (ICPEICES)*, 2016, pp. 1–6.
- [20] Z. Shuai et al., "Microgrid stability: Classification and a review," *Renew. Sustain. Energy Rev.*, vol. 58, pp. 167–179, 2016.
- [21] J. Schiffer, D. Zonetti, R. Ortega, A. M. Stanković, T. Sezi, and J. Raisch, "A survey on modeling of microgrids—From fundamental physics to phasors and voltage sources," *Automatica*, vol. 74, pp. 135–150, 2016.
- [22] M. Kabalan, P. Singh, and D. Niebur, "Large Signal Lyapunov-Based Stability Studies in Microgrids: A Review," *IEEE Trans. Smart Grid*, vol. 8, no. 5, pp. 2287–2295, 2017.
- [23] M. K. AL-Nussairi, R. Bayindir, S. Padmanaban, L. Mihet-Popa, and P. Siano, "Constant Power Loads (CPL) with Microgrids: Problem Definition, Stability Analysis and Compensation Techniques," *Energies*, vol. 10, no. 10, 2017.
- [24] E. Hossain, R. Perez, A. Nasiri, and S. Padmanaban, "A Comprehensive Review on Constant Power Loads Compensation Techniques," *IEEE Access*, vol. 6, pp. 33285–33305, 2018.
- [25] S. Sen and V. Kumar, "Microgrid modelling: A comprehensive survey," *Annu. Rev. Control*, vol. 46, pp. 216–250, 2018.
- [26] S. Marzal, R. Salas, R. González-Medina, G. Garcerá, and E. Figueres, "Current challenges and future trends in the field of communication architectures for microgrids," *Renew. Sustain. Energy Rev.*, vol. 82, pp. 3610–3622, 2018.
- [27] M. A. Hossain, H. R. Pota, M. J. Hossain, and F. Blaabjerg, "Evolution of microgrids with converter-interfaced generations: Challenges and opportunities," *Int. J. Electr. Power Energy Syst.*, vol. 109, pp. 160–186, 2019.
- [28] S. Vadi, S. Padmanaban, R. Bayindir, F. Blaabjerg, and L. Mihet-Popa, "A Review on Optimization and Control Methods Used to Provide Transient Stability in Microgrids," *Energies*, vol. 12, no. 18, 2019.
- [29] Y. Wu, Y. Wu, J. M. Guerrero, J. C. Vasquez, and J. Li, "AC Microgrid Small-Signal Modeling: Hierarchical Control Structure Challenges and Solutions," *IEEE Electr. Mag.*, vol. 7, no. 4, pp. 81–88, 2019.
- [30] K. M. Cheema, "A comprehensive review of virtual synchronous generator," *Int. J. Electr. Power Energy Syst.*, vol. 120, p. 106006, 2020.
- [31] A. Cagnano, E. De Tuglie, and P. Mancarella, "Microgrids: Overview and guidelines for practical implementations and operation," *Appl. Energy*, vol. 258, p. 114039, 2020.
- [32] Y. Ojo, J. Watson, and I. Lestas, "A Review of Reduced-Order Models for Microgrids: Simplifications vs Accuracy," 2020.
- [33] G. San, W. Zhang, X. Guo, C. Hua, H. Xin, and F. Blaabjerg, "Large-disturbance stability for power-converter-dominated microgrid: A review," *Renew. Sustain. Energy Rev.*, vol. 127, p. 109859, 2020.
- [34] D. Rebolal, M. Carpintero-Rentería, D. Santos-Martín, and M. Chinchilla, "Microgrid and Distributed Energy Resources Standards and Guidelines Review: Grid Connection and Operation Technical Requirements," *Energies*, vol. 14, no. 3, 2021.
- [35] F. Nejabatkhah, Y. W. Li, H. Liang, and R. Reza Ahrabi, "Cyber-Security of Smart Microgrids: A Survey," *Energies*, vol. 14, no. 1, 2021.
- [36] G. Shahgholian, "A brief review on microgrids: Operation, applications, modeling, and control," *Int. Trans. Electr. Energy Syst.*, vol. 31, no. 6, p. e12885, Jun. 2021.
- [37] S. Mehta and P. Basak, "A comprehensive review on control techniques for stability improvement in microgrids," *Int. Trans. Electr. Energy Syst.*, vol. 31, no. 4, p. e12822, Apr. 2021.
- [38] V. Skiparev, R. Machlev, N. R. Chowdhury, Y. Levron, E. Petlenkov, and J. Belikov, "Virtual Inertia Control Methods in Islanded Microgrids," *Energies*, vol. 14, no. 6, 2021.
- [39] N. Hosseinzadeh, A. Aziz, A. Mahmud, A. Gargoom, and M. Rabbani, "Voltage Stability of Power Systems with Renewable-Energy Inverter-Based Generators: A Review," *Electronics*, vol. 10, no. 2, 2021.
- [40] X. Lu and J. Lai, "Communication Constraints for Distributed Secondary Control of Heterogeneous Microgrids: A Survey," *IEEE Trans. Ind. Appl.*, vol. 57, no. 6, pp. 5636–5648, 2021.
- [41] F. Feng and P. Zhang, "Implicit Zbus Gauss Algorithm Revisited," *IEEE Trans. Power Syst.*, vol. 35, no. 5, pp. 4108–4111, 2020.
- [42] H. Nikkhajoei and R. Iravani, "Steady-State Model and Power Flow Analysis of Electronically-Coupled Distributed Resource Units," *IEEE Trans. Power Deliv.*, vol. 22, no. 1, pp. 721–728, 2007.

- [43] M. Z. Kamh and R. Iravani, "Unbalanced Model and Power-Flow Analysis of Microgrids and Active Distribution Systems," *IEEE Trans. Power Deliv.*, vol. 25, no. 4, pp. 2851–2858, 2010.
- [44] M. M. A. Abdelaziz, H. E. Farag, E. F. El-Saadany, and Y. A. I. Mohamed, "A Novel and Generalized Three-Phase Power Flow Algorithm for Islanded Microgrids Using a Newton Trust Region Method," *IEEE Trans. Power Syst.*, vol. 28, no. 1, pp. 190–201, 2013.
- [45] F. Mumtaz, M. H. Syed, M. A. Hosani, and H. H. Zeineldin, "A Novel Approach to Solve Power Flow for Islanded Microgrids Using Modified Newton Raphson With Droop Control of DG," *IEEE Trans. Sustain. Energy*, vol. 7, no. 2, pp. 493–503, 2016.
- [46] G. Díaz, J. Gómez-Aleixandre, and J. Coto, "Direct Backward/Forward Sweep Algorithm for Solving Load Power Flows in AC Droop-Regulated Microgrids," *IEEE Trans. Smart Grid*, vol. 7, no. 5, pp. 2208–2217, 2016.
- [47] L. Ren and P. Zhang, "Generalized Microgrid Power Flow," *IEEE Trans. Smart Grid*, vol. 9, no. 4, pp. 3911–3913, 2018.
- [48] F. Feng and P. Zhang, "Enhanced Microgrid Power Flow Incorporating Hierarchical Control," *IEEE Trans. Power Syst.*, vol. 35, no. 3, pp. 2463–2466, 2020.
- [49] M. A. Laughton, "Analysis of unbalanced polyphase networks by the method of phase co-ordinates. Part 1: System Representation in Phase of Reference," *Proc. Inst. Electr. Eng.*, vol. 115, no. 8, pp. 1163–1172, May 1968.
- [50] P. A. N. Garcia, J. L. R. Pereira, S. Carneiro, V. M. da Costa, and N. Martins, "Three-phase power flow calculations using the current injection method," *IEEE Trans. Power Syst.*, vol. 15, no. 2, pp. 508–514, 2000.
- [51] J. Arrillaga, C. P. Arnold, and B. J. Harker, *Computer Modelling of Electrical Power Systems*. Wiley, 1983.
- [52] J. M. Marinho and G. Taranto, "A hybrid three-phase single-phase power flow formulation," in *2009 IEEE Power & Energy Society General Meeting*, 2009, p. 1.
- [53] J. M. Marinho, "Time-Domain Simulation with a Flexible Positive-Sequence/Three-Phase Formulation," Ph.D. Thesis (in Portuguese), COPPE/UFRJ, 2008.
- [54] R. G. Harley, E. B. Makram, and E. G. Duran, "The effects of unbalanced networks and unbalanced faults on induction motor transient stability," *IEEE Trans. Energy Convers.*, vol. 3, no. 2, pp. 398–403, 1988.
- [55] R. G. Harley, E. B. Makram, and E. G. Duran, "The effects of unbalanced networks on synchronous and asynchronous machine transient stability," *Electr. Power Syst. Res.*, vol. 13, no. 2, pp. 119–127, 1987.
- [56] E. B. Makram, V. O. Zambrano, R. G. Harley, and J. C. Balda, "Three-Phase Modeling for Transient Stability of Large Scale Unbalanced Distribution Systems," *IEEE Power Eng. Rev.*, vol. 9, no. 5, p. 47, 1989.
- [57] R. H. Salim and R. A. Ramos, "A Model-Based Approach for Small-Signal Stability Assessment of Unbalanced Power Systems," *IEEE Trans. Power Syst.*, vol. 27, no. 4, pp. 2006–2014, 2012.
- [58] E. Nasr-Azadani, C. A. Cañizares, D. E. Olivares, and K. Bhattacharya, "Stability Analysis of Unbalanced Distribution Systems With Synchronous Machine and DFIG Based Distributed Generators," *IEEE Trans. Smart Grid*, vol. 5, no. 5, pp. 2326–2338, 2014.
- [59] M. A. Elizondo, F. K. Tuffner, and K. P. Schneider, "Three-Phase Unbalanced Transient Dynamics and Powerflow for Modeling Distribution Systems With Synchronous Machines," *IEEE Trans. Power Syst.*, vol. 31, no. 1, pp. 105–115, 2016.
- [60] N. Taranto and J. M. Marinho, "Simulation of Integrated Transmission and Distribution Networks with a Hybrid Three-Phase/Single-Phase Formulation," in *IREP Symposium*, 2017.
- [61] "IEEE Recommended Practice for Excitation System Models for Power System Stability Studies," IEEE Std 421.5-2016 (Revision of IEEE Std 421.5-2005), pp. 1–207, 2016.
- [62] A. B. Piardi, J. R. Pesente, R. B. Otto, and R. A. Ramos, "Evaluation of under-excitation limiter actuation under unbalanced load conditions," in *2014 IEEE PES General Meeting | Conference & Exposition*, 2014, pp. 1–5.
- [63] A. B. Piardi, J. R. Pesente, R. B. Otto, and R. A. Ramos, "Evaluation of Volts/Hertz and over-excitation limiters acting under unbalanced load conditions," in *2013 IEEE Power & Energy Society General Meeting*, 2013, pp. 1–5.
- [64] F. A. Mourinho, J. R. Pesente, R. B. Otto, and R. A. Ramos, "Modeling and evaluation of the protection of distributed synchronous generators connected to unbalanced systems," in *2014 IEEE PES General Meeting | Conference & Exposition*, 2014, pp. 1–5.
- [65] P. Kundur, *Power System Stability And Control*. New York: McGraw-Hill, 1994.
- [66] S. A. Papathanassiou and M. P. Papadopoulos, "Dynamic characteristics of autonomous wind–diesel systems," *Renew. Energy*, vol. 23, no. 2, pp. 293–311, 2001.
- [67] M. Datta, T. Senjyu, A. Yona, T. Funabashi, and C. Kim, "A Frequency-Control Approach by Photovoltaic Generator in a PV–Diesel Hybrid Power System," *IEEE Trans. Energy Convers.*, vol. 26, no. 2, pp. 559–571, 2011.
- [68] K. E. Yeager and J. R. Willis, "Modeling of emergency diesel generators in an 800 megawatt nuclear power plant," *IEEE Trans. Energy Convers.*, vol. 8, no. 3, pp. 433–441, 1993.
- [69] E. N. Azadani, C. Canizares, and K. Bhattacharya, "Modeling and stability analysis of distributed generation," in *2012 IEEE Power and Energy Society General Meeting*, 2012, pp. 1–8.
- [70] S. Choudhury, "A comprehensive review on issues, investigations, control and protection trends, technical challenges and future directions for Microgrid technology," *Int. Trans. Electr. Energy Syst.*, vol. 30, no. 9, p. e12446, Sep. 2020.
- [71] X. Yan and W. Zhang, "Review of VSG Control-Enabled Universal Compatibility Architecture for Future Power Systems with High-Penetration Renewable Generation," *Applied Sciences*, vol. 9, no. 7, 2019.
- [72] E. Rokrok, M. Shafie-khah, and J. P. S. Catalão, "Review of primary voltage and frequency control methods for inverter-based islanded microgrids with distributed generation," *Renew. Sustain. Energy Rev.*, vol. 82, pp. 3225–3235, 2018.
- [73] G. Denis, T. Prevost, M.-S. Debry, F. Xavier, X. Guillaud, and A. Menze, "The Migrate project: the challenges of operating a transmission grid with only inverter-based generation. A grid-forming control improvement with transient current-limiting control," *IET Renew. Power Gener.*, vol. 12, no. 5, pp. 523–529, Apr. 2018.
- [74] Z. Zou and M. Liserre, "Modeling Phase-Locked Loop-Based Synchronization in Grid-Interfaced Converters," *IEEE Trans. Energy Convers.*, vol. 35, no. 1, pp. 394–404, 2020.
- [75] J. Rocabert, A. Luna, F. Blaabjerg, and P. Rodríguez, "Control of Power Converters in AC Microgrids," *IEEE Trans. Power Electron.*, vol. 27, no. 11, pp. 4734–4749, 2012.
- [76] R. Teodorescu, F. Blaabjerg, M. Liserre, and P. C. Loh, "Proportional-resonant controllers and filters for grid-connected voltage-source converters," *IEE Proc. - Electr. Power Appl.*, vol. 153, no. 5, pp. 750–762(12), Sep. 2006.
- [77] R. Teichmann and S. Bernet, "A comparison of three-level converters versus two-level converters for low-voltage drives, traction, and utility applications," *IEEE Transactions on Industry Applications*, vol. 41, no. 3, pp. 855–865, May-June 2005.
- [78] N. Pogaku, M. Prodanovic, and T. C. Green, "Modeling, Analysis and Testing of Autonomous Operation of an Inverter-Based Microgrid," *IEEE Trans. Power Electron.*, vol. 22, no. 2, pp. 613–625, 2007.
- [79] W. Du et al., "Modeling of Grid-Forming and Grid-Following Inverters for Dynamic Simulation of Large-Scale Distribution Systems," *IEEE Trans. Power Deliv.*, p. 1, 2020.
- [80] A. Singhal, T. L. Vu, and W. Du, "Consensus Control for Coordinating Grid-Forming and Grid-Following Inverters in Microgrids," *IEEE Transactions on Smart Grid*, vol. 13, no. 5, pp. 4123–4133, Sept. 2022.
- [81] R. M. S. Filho, P. F. Seixas, P. C. Cortizo, L. A. B. Torres, and A. F. Souza, "Comparison of Three Single-Phase PLL Algorithms for UPS Applications," *IEEE Trans. Ind. Electron.*, vol. 55, no. 8, pp. 2923–2932, 2008.
- [82] S. Golestan, J. M. Guerrero, and J. C. Vasquez, "Three-Phase PLLs: A Review of Recent Advances," *IEEE Trans. Power Electron.*, vol. 32, no. 3, pp. 1894–1907, 2017.
- [83] Z. Ali, N. Christofides, L. Hadjidemetriou, E. Kyriakides, Y. Yang, and F. Blaabjerg, "Three-phase phase-locked loop synchronization algorithms for grid-connected renewable energy systems: A review," *Renew. Sustain. Energy Rev.*, vol. 90, pp. 434–452, 2018.
- [84] R. H. Lasseter, Z. Chen, and D. Pattabiraman, "Grid-Forming Inverters: A Critical Asset for the Power Grid," *IEEE J. Emerg. Sel. Top. Power Electron.*, vol. 8, no. 2, pp. 925–935, 2020.
- [85] J. Matevosyan et al., "Grid-Forming Inverters: Are They the Key for High Renewable Penetration?," *IEEE Power Energy Mag.*, vol. 17, no. 6, pp. 89–98, 2019.
- [86] W. Du, R. H. Lasseter, and A. S. Khalsa, "Survivability of Autonomous Microgrid During Overload Events," *IEEE Trans. Smart Grid*, vol. 10, no. 4, pp. 3515–3524, 2019.
- [87] K. Strunz, K. Almunem, C. Wulkow, M. Kuschke, M. Valescudero, and X. Guillaud, "Enabling 100% Renewable Power Systems Through Power Electronic Grid-Forming Converter and Control: System Integration for

- Security, Stability, and Application to Europe", in *Proceedings of the IEEE*, vol. 111, no. 7, pp. 891-915, July 2023.
- [88] A. Tayyebi, D. Groß, A. Anta, F. Kupzog, and F. Dörfler, "Frequency Stability of Synchronous Machines and Grid-Forming Power Converters," *IEEE J. Emerg. Sel. Top. Power Electron.*, vol. 8, no. 2, pp. 1004-1018, 2020.
- [89] V. Vázquez, L. M. Ortega, D. Romero, R. Ortega, O. Carranza, and J. J. Rodríguez, "Comparison of methods for controllers design of single phase inverter operating in island mode in a microgrid: Review," *Renew. Sustain. Energy Rev.*, vol. 76, pp. 256-267, 2017.
- [90] A. Micalef, "Review of the current challenges and methods to mitigate power quality issues in single-phase microgrids," *IET Gener. Transm. Distrib.*, vol. 13, no. 11, pp. 2044-2054(10), Jun. 2019.
- [91] "WECC Renewable Energy Modeling Task Force, WECC PV Power Plant Dynamic Modeling Guide." USA, 2014.
- [92] M. Cespedes and J. Sun, "Impedance Modeling and Analysis of Grid-Connected Voltage-Source Converters," *IEEE Trans. Power Electron.*, vol. 29, no. 3, pp. 1254-1261, 2014.
- [93] P. A. Mendoza-Araya and G. Venkataramanan, "Stability Analysis of AC Microgrids Using Incremental Phasor Impedance Matching," *Electr. Power Components Syst.*, vol. 43, no. 4, pp. 473-484, Feb. 2015.
- [94] X. Wang, L. Harnefors, and F. Blaabjerg, "Unified Impedance Model of Grid-Connected Voltage-Source Converters," *IEEE Transactions on Power Electronics*, vol. 33, no. 2, pp. 1775-1787, Feb. 2018.
- [95] I. Cvetkovic, D. Boroyevich, P. Mattavelli, F. C. Lee, and D. Dong, "Un-terminated, low-frequency terminal behavioral model of dc-dc converters," in *2011 Twenty-Sixth Annual IEEE Applied Power Electronics Conference and Exposition (APEC)*, 2011, pp. 1873-1880.
- [96] D. C. Ludois and G. Venkataramanan, "Simplified Terminal Behavioral Model for a Modular Multilevel Converter," *IEEE Trans. Power Electron.*, vol. 29, no. 4, pp. 1622-1631, 2014.
- [97] Z. Liu, J. Liu, D. Boroyevich, and R. Burgos, "Stability criterion of droop-controlled parallel inverters based on terminal-characteristics of individual inverters," in *2016 IEEE 8th International Power Electronics and Motion Control Conference (IPEMC-ECCE Asia)*, 2016, pp. 2958-2963.
- [98] Z. Liu, J. Liu, X. Hou, Q. Dou, D. Xue, and T. Liu, "Output Impedance Modeling and Stability Prediction of Three-Phase Paralleled Inverters With Master-Slave Sharing Scheme Based on Terminal Characteristics of Individual Inverters," *IEEE Trans. Power Electron.*, vol. 31, no. 7, pp. 5306-5320, 2016.
- [99] W. Cao, Y. Ma, F. Wang, L. M. Tolbert, and Y. Xue, "Low-Frequency Stability Analysis of Inverter-Based Islanded Multiple-Bus AC Microgrids Based on Terminal Characteristics," *IEEE Trans. Smart Grid*, vol. 11, no. 5, pp. 3662-3676, 2020.
- [100] E. H. Camm et al., "Characteristics of wind turbine generators for wind power plants," in *2009 IEEE Power & Energy Society General Meeting*, 2009, pp. 1-5.
- [101] J. Hu, Y. Huang, D. Wang, H. Yuan, and X. Yuan, "Modeling of Grid-Connected DFIG-Based Wind Turbines for DC-Link Voltage Stability Analysis," *IEEE Trans. Sustain. Energy*, vol. 6, no. 4, pp. 1325-1336, 2015.
- [102] G. M. Asher, "A doubly fed induction generator using back-to-back PWM converters supplying an isolated load from a variable speed wind turbine," *IEE Proc. - Electr. Power Appl.*, vol. 143, no. 5, pp. 380-387(7), Sep. 1996.
- [103] A. Tapia, G. Tapia, J. X. Ostolaza, and J. R. Saenz, "Modeling and control of a wind turbine driven doubly fed induction generator," *IEEE Trans. Energy Convers.*, vol. 18, no. 2, pp. 194-204, 2003.
- [104] M. Kuschke and K. Strunz, "Energy-Efficient Dynamic Drive Control for Wind Power Conversion With PMSG: Modeling and Application of Transfer Function Analysis," *IEEE J. Emerg. Sel. Top. Power Electron.*, vol. 2, no. 1, pp. 35-46, 2014.
- [105] A. Ellis, Y. Kazachkov, E. Muljadi, P. Pourbeik, and J. J. Sanchez-Gasca, "Description and technical specifications for generic WTG models — A status report," in *2011 IEEE/PES Power Systems Conference and Exposition*, 2011, pp. 1-8.
- [106] Y. Lei, A. Mullane, G. Lightbody, and R. Yacamini, "Modeling of the wind turbine with a doubly fed induction generator for grid integration studies," *IEEE Trans. Energy Convers.*, vol. 21, no. 1, pp. 257-264, 2006.
- [107] E. Muljadi and C. P. Butterfield, "Pitch-controlled variable-speed wind turbine generation," *IEEE Trans. Ind. Appl.*, vol. 37, no. 1, pp. 240-246, 2001.
- [108] N. W. Miller, J. J. Sanchez-Gasca, W. W. Price, and R. W. Delmerico, "Dynamic modeling of GE 1.5 and 3.6 MW wind turbine-generators for stability simulations," in *2003 IEEE Power Engineering Society General Meeting (IEEE Cat. No.03CH37491)*, 2003, vol. 3, pp. 1977-1983 Vol. 3.
- [109] F. Mei and B. Pal, "Modal Analysis of Grid-Connected Doubly Fed Induction Generators," *IEEE Trans. Energy Convers.*, vol. 22, no. 3, pp. 728-736, 2007.
- [110] V. D. and V. John, "Dynamic Modeling and Analysis of Buck Converter based Solar PV Charge Controller for Improved MPPT Performance," in *2018 IEEE International Conference on Power Electronics, Drives and Energy Systems (PEDES)*, 2018, pp. 1-6.
- [111] A. Reza Reisi, M. Hassan Moradi, and S. Jamasb, "Classification and comparison of maximum power point tracking techniques for photovoltaic system: A review," *Renew. Sustain. Energy Rev.*, vol. 19, pp. 433-443, 2013.
- [112] H. Hu, S. Harb, N. Kutkut, I. Batarseh, and Z. J. Shen, "Power decoupling techniques for micro-inverters in PV systems—a review," in *2010 IEEE Energy Conversion Congress and Exposition*, 2010, pp. 3235-3240.
- [113] S.-K. Kim, J.-H. Jeon, C.-H. Cho, E.-S. Kim, and J.-B. Ahn, "Modeling and simulation of a grid-connected PV generation system for electromagnetic transient analysis," *Sol. Energy*, vol. 83, no. 5, pp. 664-678, 2009.
- [114] Á. Ortega and F. Milano, "Generalized Model of VSC-Based Energy Storage Systems for Transient Stability Analysis," *IEEE Trans. Power Syst.*, vol. 31, no. 5, pp. 3369-3380, 2016.
- [115] D. Bazargan, S. Filizadeh, and A. M. Gole, "Stability Analysis of Converter-Connected Battery Energy Storage Systems in the Grid," *IEEE Trans. Sustain. Energy*, vol. 5, no. 4, pp. 1204-1212, 2014.
- [116] M. Farrokhbadi, S. König, C. A. Cañizares, K. Bhattacharya, and T. Leibfried, "Battery Energy Storage System Models for Microgrid Stability Analysis and Dynamic Simulation," *IEEE Trans. Power Syst.*, vol. 33, no. 2, pp. 2301-2312, 2018.
- [117] D. M. Rosewater, D. A. Copp, T. A. Nguyen, R. H. Byrne, and S. Santoso, "Battery Energy Storage Models for Optimal Control," *IEEE Access*, vol. 7, pp. 178357-178391, 2019.
- [118] M. Bahramipناه, D. Torregrossa, R. Cherkaoui, and M. Paolone, "A Decentralized Adaptive Model-Based Real-Time Control for Active Distribution Networks Using Battery Energy Storage Systems," *IEEE Trans. Smart Grid*, vol. 9, no. 4, pp. 3406-3418, 2018.
- [119] J. Roach, "Microsoft tests hydrogen fuel cells for backup power at data-centers," Microsoft, 2020. [Online]. Available: <https://news.microsoft.com/innovation-stories/hydrogen-datacenters/>.
- [120] Y. Zhu and K. Tomsovic, "Development of models for analyzing the load-following performance of microturbines and fuel cells," *Electr. Power Syst. Res.*, vol. 62, no. 1, pp. 1-11, 2002.
- [121] M. Y. El-Sharkh, A. Rahman, M. S. Alam, P. C. Byrne, A. A. Sakla, and T. Thomas, "A dynamic model for a stand-alone PEM fuel cell power plant for residential applications," *J. Power Sources*, vol. 138, no. 1, pp. 199-204, 2004.
- [122] A. M. Azmy, "Simulation and Management of Distributed Generating Units using Intelligent Techniques." Germany: University Duisburg-Essen, Ph.D. Thesis, 2006.
- [123] T. Lan and K. Strunz, "Multiphysics Transients Modeling of Solid Oxide Fuel Cells: Methodology of Circuit Equivalents and Use in EMTP-Type Power System Simulation," *IEEE Trans. Energy Convers.*, vol. 32, no. 4, pp. 1309-1321, 2017.
- [124] T. Lan and K. Strunz, "Modeling of the Enthalpy Transfer Using Electric Circuit Equivalents: Theory and Application to Transients of Multi-Carrier Energy Systems," *IEEE Trans. Energy Convers.*, vol. 34, no. 4, pp. 1720-1730, 2019.
- [125] T. Lan and K. Strunz, "Modeling of multi-physics transients in PEM fuel cells using equivalent circuits for consistent representation of electric, pneumatic, and thermal quantities," *Int. J. Electr. Power Energy Syst.*, vol. 119, p. 105803, 2020.
- [126] D. P. Ariyasinghe and D. M. Vilathgamuwa, "Stability analysis of microgrids with constant power loads," in *2008 IEEE International Conference on Sustainable Energy Technologies*, 2008, pp. 279-284.
- [127] M. Ahmed, L. Meegahapola, A. Vahidnia, and M. Datta, "Analysis and mitigation of low-frequency oscillations in hybrid AC/DC microgrids with dynamic loads," *IET Gener. Transm. Distrib.*, vol. 13, no. 9, pp. 1477-1488, May 2019.
- [128] T. Zhang, A. E. Emanuel, and J. A. Orr, "Enhancing Induction Motor Recovery in Microgrids via Adaptive Voltage Regulation," in *2019 IEEE Power & Energy Society General Meeting (PESGM)*, 2019, pp. 1-5.
- [129] M. Ahmed, L. Meegahapola, A. Vahidnia, and M. Datta, "Stability and Control Aspects of Microgrid Architectures—A Comprehensive Review," *IEEE Access*, vol. 8, pp. 144730-144766, 2020.

- [130] B. V. Solanki, A. Raghurajan, K. Bhattacharya, and C. A. Cañizares, "Including Smart Loads for Optimal Demand Response in Integrated Energy Management Systems for Isolated Microgrids," *IEEE Trans. Smart Grid*, vol. 8, no. 4, pp. 1739–1748, 2017.
- [131] T. A. Papadopoulos, E. N. Tzanidakis, P. N. Papadopoulos, P. Crolla, G. K. Papagiannis, and G. M. Burt, "Aggregate load modeling in microgrids using online measurements," in *MedPower 2014*, 2014, pp. 1–8.
- [132] L. G. Meegahapola, D. Robinson, A. P. Agalgaonkar, S. Perera, and P. Ciufu, "Microgrids of Commercial Buildings: Strategies to Manage Mode Transfer From Grid Connected to Islanded Mode," *IEEE Trans. Sustain. Energy*, vol. 5, no. 4, pp. 1337–1347, 2014.
- [133] C. H. Dharmakeerthi, N. Mithulananthan, and A. Atputharajah, "Development of dynamic EV load model for power system oscillatory stability studies," in *2014 Australasian Universities Power Engineering Conference (AUPEC)*, 2014, pp. 1–6.
- [134] V. Vittal, J. D. McCalley, P. M. Anderson, and A. A. Fouad, "Load Modelling," in *Power System Control and Stability*, 3rd ed., New Jersey: Wiley-IEEE Press, 2019, p. 832.
- [135] Y. Zhu, *Power System Loads and Power System Stability*, 1st ed. Cham, Switzerland: Springer, 2020.
- [136] M. Ahmed, A. Vahidnia, L. Meegahapola, and M. Datta, "Small signal stability analysis of a hybrid AC/DC microgrid with static and dynamic loads," in *2017 Australasian Universities Power Engineering Conference (AUPEC)*, 2017, pp. 1–6.
- [137] A. Arif, Z. Wang, J. Wang, B. Mather, H. Bashualdo, and D. Zhao, "Load Modeling—A Review," *IEEE Trans. Smart Grid*, vol. 9, no. 6, pp. 5986–5999, 2018.
- [138] D. E. Olivares et al., "Trends in Microgrid Control," *IEEE Trans. Smart Grid*, vol. 5, no. 4, pp. 1905–1919, 2014.
- [139] S. Parhizi, H. Lotfi, A. Khodaei, and S. Bahramirad, "State of the Art in Research on Microgrids: A Review," *IEEE Access*, vol. 3, pp. 890–925, 2015.
- [140] H. Bevrani, B. François, and T. Ise, *Microgrid Dynamics and Control*. Wiley, 2017.
- [141] A. Bidram and A. Davoudi, "Hierarchical Structure of Microgrids Control System," *IEEE Trans. Smart Grid*, vol. 3, no. 4, pp. 1963–1976, 2012.
- [142] N. Hatziargyriou, *Microgrid: architectures and control*, 1st ed. Wiley-IEEE Press, 2014.
- [143] J. M. Guerrero, M. Chandorkar, T. Lee, and P. C. Loh, "Advanced Control Architectures for Intelligent Microgrids—Part I: Decentralized and Hierarchical Control," *IEEE Trans. Ind. Electron.*, vol. 60, no. 4, pp. 1254–1262, 2013.
- [144] J. M. Guerrero, J. C. Vasquez, J. Matas, L. G. de Vicuna, and M. Castilla, "Hierarchical Control of Droop-Controlled AC and DC Microgrids—A General Approach Toward Standardization," *IEEE Trans. Ind. Electron.*, vol. 58, no. 1, pp. 158–172, 2011.
- [145] F. Katiraei, R. Iravani, N. Hatziargyriou, and A. Dimeas, "Microgrids management," *IEEE Power Energy Mag.*, vol. 6, no. 3, pp. 54–65, 2008.
- [146] A. Vasilakis, I. Zafeiratou, D. T. Lagos, and N. D. Hatziargyriou, "The Evolution of Research in Microgrids Control," *IEEE Open Access J. Power Energy*, vol. 7, pp. 331–343, 2020.
- [147] T. L. Vandoorn, J. C. Vasquez, J. De Kooning, J. M. Guerrero, and L. Vandeveldel, "Microgrids: Hierarchical Control and an Overview of the Control and Reserve Management Strategies," *IEEE Ind. Electron. Mag.*, vol. 7, no. 4, pp. 42–55, 2013.
- [148] D. E. Olivares, C. A. Cañizares, and M. Kazerani, "A Centralized Energy Management System for Isolated Microgrids," *IEEE Trans. Smart Grid*, vol. 5, no. 4, pp. 1864–1875, 2014.
- [149] I. Serban, S. Céspedes, C. Marinescu, C. A. Azurdia-Meza, J. S. Gómez, and D. S. Hueichapan, "Communication Requirements in Microgrids: A Practical Survey," *IEEE Access*, vol. 8, pp. 47694–47712, 2020.
- [150] E. Espina, J. Llanos, C. Burgos-Mellado, R. Cárdenas-Dobson, M. Martínez-Gómez, and D. Sáez, "Distributed Control Strategies for Microgrids: An Overview," *IEEE Access*, vol. 8, pp. 193412–193448, 2020.
- [151] M. Yazdani and A. Mehrizi-Sani, "Distributed Control Techniques in Microgrids," *IEEE Trans. Smart Grid*, vol. 5, no. 6, pp. 2901–2909, 2014.
- [152] A. Bidram, V. Nasirian, A. Davoudi, and F. Lewis, *Cooperative Synchronization in Distributed Microgrid Control*, 1st ed. Springer International Publishing, 2017.
- [153] Y. Han, K. Zhang, H. Li, E. A. A. Coelho, and J. M. Guerrero, "MAS-Based Distributed Coordinated Control and Optimization in Microgrid and Microgrid Clusters: A Comprehensive Overview," *IEEE Transactions on Power Electronics*, vol. 33, no. 8, pp. 6488–6508, 2018.
- [154] K. Strunz and E. Carlson, "Nested Fast and Simultaneous Solution for Time-Domain Simulation of Integrative Power-Electric and Electronic Systems," *IEEE Trans. Power Deliv.*, vol. 22, no. 1, pp. 277–287, 2007.
- [155] U. N. Gnanarathna, A. M. Gole, and R. P. Jayasinghe, "Efficient Modeling of Modular Multilevel HVDC Converters (MMC) on Electromagnetic Transient Simulation Programs," *IEEE Trans. Power Deliv.*, vol. 26, no. 1, pp. 316–324, 2011.
- [156] J. G. Kassakian, M. F. Schlecht, and G. C. Verghese, *Principles of Power Electronics*. Addison-Wesley, 1991.
- [157] S. R. Sanders, J. M. Noworolski, X. Z. Liu, and G. C. Verghese, "Generalized averaging method for power conversion circuits," *IEEE Trans. Power Electron.*, vol. 6, no. 2, pp. 251–259, 1991.
- [158] V. Venkatasubramanian, H. Schattler, and J. Zaborszky, "Fast time-varying phasor analysis in the balanced three-phase large electric power system," *IEEE Trans. Automat. Contr.*, vol. 40, no. 11, pp. 1975–1982, 1995.
- [159] A. M. Stankovic, S. R. Sanders, and T. Aydin, "Dynamic phasors in modeling and analysis of unbalanced polyphase AC machines," *IEEE Trans. Energy Convers.*, vol. 17, no. 1, pp. 107–113, 2002.
- [160] K. Strunz, R. Shintaku, and F. Gao, "Frequency-Adaptive Network Modeling for Integrative Simulation of Natural and Envelope Waveforms in Power Systems and Circuits," *IEEE Trans. Circuits Syst. I Regul. Pap.*, vol. 53, no. 12, pp. 2788–2803, 2006.
- [161] P. Zhang, J. R. Marti, and H. W. Dommel, "Shifted-Frequency Analysis for EMT Simulation of Power-System Dynamics," *IEEE Trans. Circuits Syst. I Regul. Pap.*, vol. 57, no. 9, pp. 2564–2574, 2010.
- [162] F. Gao and K. Strunz, "Frequency-Adaptive Power System Modeling for Multiscale Simulation of Transients," *IEEE Trans. Power Syst.*, vol. 24, no. 2, pp. 561–571, 2009.
- [163] Y. Xia, Y. Chen, Y. Song, and K. Strunz, "Multi-Scale Modeling and Simulation of DFIG-Based Wind Energy Conversion System," *IEEE Trans. Energy Convers.*, vol. 35, no. 1, pp. 560–572, 2020.
- [164] W. Ren et al., "Interfacing Issues in Real-Time Digital Simulators," *IEEE Trans. Power Deliv.*, vol. 26, no. 2, pp. 1221–1230, 2011.
- [165] J. Vega-Herrera, C. Rahmann, F. Valencia, and K. Strunz, "Analysis and Application of Quasi-Static and Dynamic Phasor Calculus for Stability Assessment of Integrated Power Electric and Electronic Systems," *IEEE Trans. Power Syst.*, vol. 36, no. 3, pp. 1750–1760, 2021.
- [166] K. P. Schneider, F. K. Tuffner, M. A. Elizondo, J. Hansen, J. C. Fuller, and D. P. Chassin, "Adaptive Dynamic Simulations for Distribution Systems Using Multistate Load Models," *IEEE Trans. Smart Grid*, vol. 10, no. 2, pp. 2257–2266, 2019.
- [167] J. Mahseredjian, "Tools and techniques for EMT simulations research activities." Presentation, Polytechnique Montreal, 2019.
- [168] M. A. Elizondo, F. K. Tuffner, and K. P. Schneider, "Simulation of Inrush Dynamics for Unbalanced Distribution Systems Using Dynamic-Phasor Models," *IEEE Trans. Power Syst.*, vol. 32, no. 1, pp. 633–642, 2017.
- [169] W. Du, K. P. Schneider, F. K. Tuffner, Z. Chen, and R. H. Lasseter, "Modeling of Grid-Forming Inverters for Transient Stability Simulations of an all Inverter-based Distribution System," in *2019 IEEE Power & Energy Society Innovative Smart Grid Technologies Conference (ISGT)*, 2019, pp. 1–5.
- [170] K. P. Schneider et al., "Enabling Resiliency Operations Across Multiple Microgrids With Grid Friendly Appliance Controllers," *IEEE Trans. Smart Grid*, vol. 9, no. 5, pp. 4755–4764, 2018.
- [171] F. K. Tuffner, K. P. Schneider, J. Hansen, and M. A. Elizondo, "Modeling Load Dynamics to Support Resiliency-Based Operations in Low-Inertia Microgrids," *IEEE Trans. Smart Grid*, vol. 10, no. 3, pp. 2726–2737, 2019.
- [172] W. Du, A. Singhal, F. K. Tuffner, and K. P. Schneider, "Comparison of Electromagnetic Transient and Phasor-based Simulation for the Stability of Grid-Forming-Inverter-based Microgrids," in *2021 IEEE Power & Energy Society Innovative Smart Grid Technologies Conference (ISGT)*, 2021, pp. 1–5.
- [173] P. Ferraro, E. Crisostomi, M. Raugi, and F. Milano, "Analysis of the Impact of Microgrid Penetration on Power System Dynamics," *IEEE Trans. Power Syst.*, vol. 32, no. 5, pp. 4101–4109, 2017.
- [174] Y. Xu, C. Liu, K. P. Schneider, F. K. Tuffner, and D. T. Ton, "Microgrids for Service Restoration to Critical Load in a Resilient Distribution System," *IEEE Trans. Smart Grid*, vol. 9, no. 1, pp. 426–437, 2018.
- [175] K. P. Schneider, J. C. Fuller, and D. P. Chassin, "Multi-State Load Models for Distribution System Analysis," *IEEE Trans. Power Syst.*, vol. 26, no. 4, pp. 2425–2433, 2011.
- [176] ETAP, "eMTCosim." [Online]. Available: <https://etap.com/product/electromagnetic-transient-co-simulation>.

- [177] B. Palmintier, D. Krishnamurthy, P. Top, S. Smith, J. Daily, and J. Fuller, "Design of the HELICS high-performance transmission-distribution-communication-market co-simulation framework," in *2017 Workshop on Modeling and Simulation of Cyber-Physical Energy Systems (MSCPES)*, 2017, pp. 1–6.
- [178] F. Calero, C. A. Cañizares, and K. Bhattacharya, "Dynamic Modeling of Battery Energy Storage and Applications in Transmission Systems," *IEEE Transactions on Smart Grid*, vol. 12, no. 1, January 2021, pp. 589–598.
- [179] Y. Shi, D. Xu, J. Su, N. Liu, H. Yu, and H. Xu, "Black-Box Behavioral Modeling of Voltage and Frequency Response Characteristic for Islanded Microgrid," *Energies*, vol. 12, no. 11, 2019.
- [180] F. O. Resende, J. Matevosyan, and J. V. Milanovic, "Application of dynamic equivalence techniques to derive aggregated models of active distribution network cells and microgrids," in *2013 IEEE Grenoble Conference*, 2013, pp. 1–6.
- [181] S. M. Zali and J. V. Milanović, "Generic Model of Active Distribution Network for Large Power System Stability Studies," *IEEE Trans. Power Syst.*, vol. 28, no. 3, pp. 3126–3133, 2013.
- [182] F. Conte et al., "Dynamic equivalent modelling of active distribution networks for TSO-DSO interactions," in *2017 IEEE PES Innovative Smart Grid Technologies Conference Europe (ISGT-Europe)*, 2017, pp. 1–6.
- [183] F. O. Resende and J. A. P. Lopes, "Development of Dynamic Equivalents for MicroGrids using System Identification Theory," in *2007 IEEE Lausanne Power Tech*, 2007, pp. 1033–1038.
- [184] P. N. Papadopoulos, T. A. Papadopoulos, P. Crolla, A. J. Roscoe, G. K. Papagiannis, and G. M. Burt, "Measurement-based analysis of the dynamic performance of microgrids using system identification techniques," *IET Gener. Transm. Distrib.*, vol. 9, no. 1, pp. 90–103, Jan. 2015.
- [185] C. Moreira, F. Resende, and J. P. Lopes, "Identification of dynamic equivalents for microgrids with high penetration of solar energy using artificial neural networks," in *3rd European PV-Hybrid and MiniGrid Conference*, 2006.
- [186] C. Han, D. Changhong, and L. Dalu, "Recurrent Neural Network-based Dynamic Equivalencing in Power System," in *2007 IEEE International Conference on Control and Automation*, 2007, pp. 2396–2399.
- [187] P. N. Papadopoulos, T. A. Papadopoulos, P. Crolla, A. J. Roscoe, G. K. Papagiannis, and G. M. Burt, "Black-box dynamic equivalent model for microgrids using measurement data," *IET Gener. Transm. Distrib.*, vol. 8, no. 5, pp. 851–861, May 2014.
- [188] A. Francés, R. Asensi, O. García, R. Prieto, and J. Uceda, "The performance of polytopic models in smart DC microgrids," in *2016 IEEE Energy Conversion Congress and Exposition (ECCE)*, 2016, pp. 1–8.
- [189] G. Guarderas, A. Francés, R. Asensi, and J. Uceda, "Large-signal black-box behavioral modeling of grid-supporting power converters in AC microgrids," in *2017 IEEE 6th International Conference on Renewable Energy Research and Applications (ICRERA)*, 2017, pp. 153–158.
- [190] A. Francés, R. Asensi, O. García, R. Prieto, and J. Uceda, "How to model a DC microgrid: Towards an automated solution," in *2017 IEEE Second International Conference on DC Microgrids (ICDCM)*, 2017, pp. 609–616.
- [191] A. Francés-Roger, A. Anvari-Moghaddam, E. Rodríguez-Díaz, J. C. Vasquez, J. M. Guerrero, and J. Uceda, "Dynamic Assessment of COTS Converters-Based DC Integrated Power Systems in Electric Ships," *IEEE Trans. Ind. Informatics*, vol. 14, no. 12, pp. 5518–5529, 2018.
- [192] A. Francés, R. Asensi, O. García, R. Prieto, and J. Uceda, "Modeling Electronic Power Converters in Smart DC Microgrids—An Overview," *IEEE Trans. Smart Grid*, vol. 9, no. 6, pp. 6274–6287, 2018.
- [193] D. Xu, Y. Shi, J. Su, and C. Feng, "Identification Modeling Method of Voltage Frequency Response Model for Microgrid in Islanded Mode," in *2019 IEEE 10th International Symposium on Power Electronics for Distributed Generation Systems (PEDG)*, 2019, pp. 762–767.
- [194] IEEE Power and Energy Society Technical Report PES-TR71, "Microgrid Protection Systems," 2019.
- [195] C. Cavaliere, V. Farias, and M. Kaban, "Microgrid Protection: A Case Study of a Real-World Industry-Grade Microgrid," in *2021 IEEE Kansas Power and Energy Conference (KPEC)*, 2021, pp. 1–5.
- [196] M. W. Altaf, M. T. Arif, S. N. Islam, and M. E. Haque, "Microgrid Protection Challenges and Mitigation Approaches—A Comprehensive Review," *IEEE Access*, vol. 10, pp. 38895–38922, 2022.
- [197] A. Dagar, P. Gupta, and V. Niranjan, "Microgrid protection: A comprehensive review," *Renew. Sustain. Energy Rev.*, vol. 149, p. 111401, 2021.